



CABLE MANUFACTURING & ASSEMBLY CO. INC.

COMPONENT CATALOG

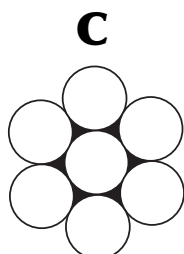

Table of Contents

I.	Cable Specifications	1
II.	PlastiCable Specifications.....	2 – 3
III.	Cable End Fittings.....	4 – 16
IV.	Solid Core Wire/Terminations.....	17 – 18
V.	Cycle-Flex Cable Specifications.....	19
VI.	Cycle-Flex Cable End Fittings.....	20 – 27
VII.	Conduit Specifications.....	28
VIII.	Remote Actuation Systems.....	29 – 37
IX.	Conduit End Fittings.....	38 – 42



COMMERCIAL CABLE SPECIFICATIONS



1 x 7

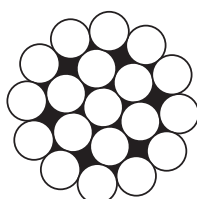

1 x 19

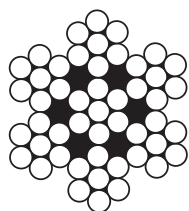

7 x 7

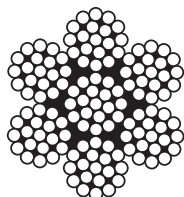

7 x 19

Diameter in./mm	Tolerance (+) in./mm	Galvanized Min. Breaking Strength Lb./ Kg.	EA Value x103	CMA Part No.*	Stainless Steel Min. Breaking Strength Lb./ Kg.	EA Value x103	Weight per M Ft. Lb./ Kg.
1/32/0.8	.005/0.13	Available in Stainless Steel Only		—	S031C	125/ 57	13 2/ 0.9
3/64/1.2	.005/0.13	G047C	375/ 170	30	S047C	375/ 170	29 5.2/ 2.4
1/16/1.6	.006/0.15	G063C	500/ 227	55	S063C	500/ 227	52 8.5/ 3.9
5/64/2.0	.008/0.20	G078C	800/ 363	84	S078C	800/ 363	80 14/ 6.3
3/32/2.4	.009/0.23	G094C	1,200/ 544	121	S094C	1,200/ 544	116 21/ 9.5
1/8/3.2	.013/0.33	G125C	1,830/ 830	215	S125C	1,830/ 830	205 32/ 15
5/32/4.0	.016/0.41	G156C	2,940/1,333	215	S156C	2,940/1,333	320 50/ 23
3/16/4.8	.013/0.33	G188C	3,990/1,810	215	S188C	3,990/1,810	464 72/ 33
7/32/5.6	.015/0.38	G219C	5,400/2,449	659	S219C	5,400/2,449	630 98/ 44
1/4/6.4	.018/0.46	G250C	6,650/3,016	859	S250C	6,650/3,016	821 120/ 54
1/32/0.8	.003/0.08	G031E	175/ 79	13	S031E	150/ 68	12 2/ 0.9
3/64/1.2	.003/0.08	G045E	350/ 159	18	S045E	300/ 136	21 4.3/1.95
3/64/1.2	.005/0.13	G047E	375/ 170	29	S047E	335/ 152	28 5.2/ 2.4
1/16/1.6	.006/0.15	G063E	500/ 227	52	S063E	500/ 227	50 8.5/ 3.9
5/64/2.0	.008/0.20	G078E	800/ 363	80	S078E	800/ 363	76 14.2/ 6.5
3/32/2.4	.009/0.23	G094E	1,200/ 544	116	S094E	1,200/ 544	111 20/ 9
1/8/3.2	.013/0.33	G125E	2,100/ 952	205	S125E	2,100/ 952	196 35/ 16
5/32/4.0	.016/0.41	G156E	3,300/1,497	320	S156E	3,300/1,497	305 57/ 26
3/16/4.8	.013/0.33	G188E	4,700/2,132	464	S188E	4,700/2,132	443 78/ 35
7/32/5.6	.015/0.38	G219E	6,300/2,857	630	S219E	6,300/2,857	601 101/ 46
1/4/6.4	.018/0.46	G250E	8,200/3,719	821	S250E	8,200/3,719	783 135/ 61
9/32/7.1	.020/0.51	G281E	9,900/4,490	1037	S281E	9,900/4,490	990 172/ 78
5/16/7.9	.023/0.58	G313E	12,500/5,669	1287	S313E	12,500/5,669	1228 210/ 95
3/8/9.5	.026/0.66	G375E	18,000/8,163	1847	S375E	18,000/8,163	1763 305/ 138
1/32/0.8	.005/0.13	Available in Stainless Steel Only		—	S031N	115/ 52	9 1.5/ 0.6
1/32/0.8	.005/0.13	Available in Stainless Steel Only		—	S036N	150/ 56	11 1.5/ 0.6
3/64/1.2	.006/0.15	G047N	270/ 122	22	S047N	270/ 122	20 4.1/ 1.9
1/16/1.6	.010/0.25	G063N	480/ 218	40	S063N	480/ 5218	36 7.5/ 3.4
5/64/2.0	.010/0.25	G078N	650/ 295	61	S078N	650/ 295	55 12/ 5.5
3/32/2.4	.012/0.30	G094N	920/ 417	88	S094N	920/ 417	80 16/ 7
1/8/3.2	.014/0.36	G125N	1,700/ 771	156	S125N	1,700/ 771	141 29/ 13
5/32/4.0	.016/0.41	G156N	2,600/1,179	243	S156N	2,400/1,088	220 45/ 20
3/16/4.8	.018/0.46	G188N	3,700/1,678	353	S188N	3,700/1,678	319 61/ 28
7/32/5.6	.018/0.46	G219N	4,800/2,177	479	S219N	4,800/2,177	433 82/ 37
1/4/ 6.4	.018/0.46	G250N	6,100/2,766	624	S250N	6,100/2,766	564 107/ 49
9/32/7.1	.020/0.51	G281N	7,400/3,356	788	S281N	7,400/3,356	713 135/ 61
5/16/7.9	.022/0.56	G313N	9,200/4,172	977	S313N	9,100/4,127	884 166/ 75
3/8/9.5	.026/0.66	G375N	13,300/6,032	1403	S375N	12,600/5,714	1269 238/ 108
1/16/1.6	.010/0.25	G063T	480/ 218	35	S063T	480/ 218	31 8.1/ 3.7
3/32/2.4	.012/0.30	G094T	1,000/ 454	78	S094T	920/ 417	70 16/ 7.3
1/8/3.2	.014/0.36	G125T	2,000/ 907	138	S125T	1,760/ 798	123 30/13.6
5/32/4.0	.016/0.41	G156T	2,800/1,270	215	S156T	2,400/1,088	192 44/ 20
3/16/4.8	.018/0.46	G188T	4,200/3,485	312	S188T	3,700/1,678	279 63/ 29
7/32/5.6	.018/0.46	G219T	5,600/2,540	423	S219T	5,000/2,268	379 85/ 39
1/4/6.4	.018/0.46	G250T	7,000/3,175	551	S250T	6,100/2,766	493 108/ 49
9/32/7.1	.020/0.51	G281T	8,000/3,628	697	S281T	7,800/3,537	623 140/263
5/16/7.9	.022/0.56	G313T	9,800/4,444	864	S313T	9,000/4,082	773 175/ 79
3/8/9.5	.026/0.66	G375T	14,400/6,531	1240	S375T	12,000/5,443	1110 245/ 111

NOTE: CMA cable part numbers contain a **prefix** which designates the cable material as well as a **Suffix** which designates the cable construction.

Prefix: G-Galvanized or S-Stainless Steel **Suffix:** C-1x7, E-1x9, N-7x7, T-7x19 **Suffix:** D-Dry or A-Lubricated

All cable is supplied dry (D) unless otherwise specified.



PLASTICABLE

Thermoplastic Coated Cable

Cable life and/or the appearance of any assembly can be enhanced by specifying CMA PlastiCable. The pressure extruded thermoplastic coatings become an integral part of the cable and are highly recommended for use with lubricated cable in pulley applications. The coating seals out contaminants, retains cable lubrication, cushions the strands, resists abrasion and increases the life cycle capability of cable used in flexing applications. CMA’s extensive background in cable coating technology and extrusion capability produces smooth, uniform and concentric coatings of high quality. Our standard “PC” resins, listed below, offer a selection of choices and colors suitable for pressure extrusion on cable. For specific recommendations based on your requirements or information on special and custom coatings, please contact CMA Sales and Engineering departments.

Standard PlastiCable Coatings

Material:	Part Number	Description	Typical Uses/Advantages
Nylon (Polyamide)	PC 100	A very flexible and abrasion-resistant resin for use in high life cycle applications. Nylon 11. Color – Slightly gray/translucent tint.	Thin wall & pulley applications – standard coating for Cycle-Flex miniature drive cables. Heat stabilized.
	PC 110	General purpose resin with adequate flexibility and abrasion resistance. Nylon 6. Color – Milky white/ green tint	Most applications for cable 1/16” & larger. Lanyards, restraint cables.
	PC 113	General purpose weather – resistant resin similar to PC 110. Nylon 6. Color - Black	Most outdoor cable uses for larger diameter cables. Heat & light stabilized.
	PC 114	Very flexible and abrasion resistant for larger diameter cables in pulley applications. Nylon 11.	High life cycle pulley applications, physical fitness equipment. Heat & light stabilized.
	PC 115	Relatively stiff, higher heat, chemical and abrasion-resistant resins. Nylon 612. Color - Clear	Cable controls, lanyards , etc.
Vinyl (polyvinyl chloride)	PC 300	General purpose PVC resistant to fatigue, high flexibility. Color- Clear	High flexibility, appearance applications. Readily color matched security cables, lanyards.
	PC 301	Color – White/Opaque.	Same as PC 300.
	PC 302	Color – Black/Opaque.	Good mechanical properties with excellent flame resistance.
	PC 303	Color – Yellow/Opaque.	Same as PC 300
	PC 304	Color – Green/Opaque.	Same as PC 300
	PC 305	Color – Blue/Opaque.	Same as PC 300
	PC 307	Color – Red/Opaque.	Same as PC 300
TPE (Thermoplastic Elstomer)	PC 904	Extrusion grade resin with rubber-like properties. Highly resistant to moisture and chemicals, good flexibility.	Good for outdoor applications, tailgate cables, parts requiring flexibility and weather resistance.

Notes: 1. Other coatings are available such as polyethylene, polypropylene, urethane, etc. Custom resins and colors are available to suit your application. Contact CMA Sales and Engineering departments for additional information.



How To Specify PlastiCable

- Select the proper bare cable diameter and part number from those listed on this page.
- Determine which "PC" resin will meet your requirements. Take into consideration cost, life expectancy, environment, etc.
- Select O.D. of coating and refer to the following for information pertaining to diameters, tolerances, and part numbers.
- PlastiCable™ part number is comprised of: bare cable part number/suffix for coating diameter followed by PC resin part number.

The CMA numbering system, shown below, permits you to specify any standard or custom diameter, PC resin or color for custom coated cable.

S125TD188113
Part Number

S	125	T	D	188	113
Cable Material (Stainless Steel)	Cable Diameter	Construction (7x19)	Lubrication (Dry)	Coating Diameter (Suffix)	PC Resin Part Number (nylon PC 113)
Stainless Steel (S) Galvanized (G)			Dry (D) Lubricated (A)		

See chart below

PlastiCable Specifications

BARE CABLE DIAMETER in./ mm	OD AFTER COATING in./ mm	STANDARD TOLERANCE + Only in./ mm	APPROX. WEIGHT of PLASTIC Per M Feet		COATING DIAMETER SUFFIX
			Lb.	Kg.	
3/64/ 1.2 (047)	1/16/ 1.6	.010/ 0.25	2	.9	063
	5/64/ 2.0	.010/ 0.25	3	1.4	078
	3/32/ 2.4	.012/ 0.30	5	2.3	094
	1/8/ 3.2	.014/ 0.36	7	3.2	125
1/16/ 1.6 (063)	5/64/ 2.0	.010/ 0.25	2	.9	078
	3/32/ 2.4	.012/ 0.30	3	1.4	094
	1/8/ 3.2	.014/ 0.36	6	2.7	125
3/32/ 2.4 (094)	1/8/ 3.2	.014/ 0.36	4	1.8	125
	5/32/ 4.0	.016/ 0.41	9	4.1	156
	3/16/ 4.8	.016/ 0.41	13	5.9	188
	5/32/ 4.0	.018/ 0.46	6	2.7	156
1/8/ 3.2 (125)	3/16/ 4.8	.018/ 0.46	11	5	188
	7/32/ 5.6	.018/ 0.46	16	7.3	219
	1/4/ 6.5	.018/ 0.46	22	10	250
	3/16/ 4.8	.018/ 0.46	5	2.3	188
5/32/ 4.0 (156)	7/32/ 5.6	.018/ 0.46	11	5	219
	1/4/ 6.5	.018/ 0.46	19	8.6	250
	1/4/ 6.5	.018/ 0.46	14	6.4	250
3/16/ 4.8 (188)	5/16/ 7.9	.022/ 0.56	28	12.7	312
	3/8/ 9.5	.022/ 0.56	51	23	375
	7/32/ 5.6	.022/ 0.56	25	11.3	312
7/32/ 5.6 (218)	3/8/ 9.5	.022/ 0.56	44	20	375
	1/4/ 6.4	.022/ 0.56	17	7.7	312
	3/8/ 9.5	.022/ 0.56	39	17.7	375
9/32/ 7.1 (281)	3/8/ 9.5	.022/ 0.56	31	14.1	375
	7/16/ 11.1	.025/ 0.64	52	23.6	437
	5/16/ 7.9	.025/ 0.64	25	11.3	375
5/16/ 7.9 (312)	7/16/ 11.1	.025/ 0.64	47	21.3	437
	3/8/ 9.5	.025/ 0.64	30	13.6	437
	7/16/ 11.1	.025/ 0.64	52	23.6	500
3/8/ 9.5 (375)	1/2/ 12.7	.025/ 0.64			



CMA 10 SERIES EYE

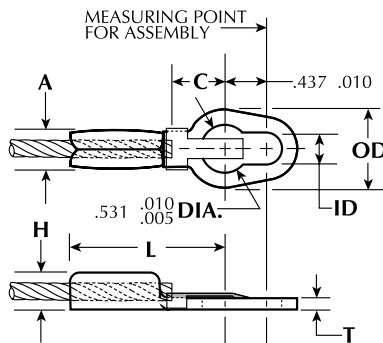
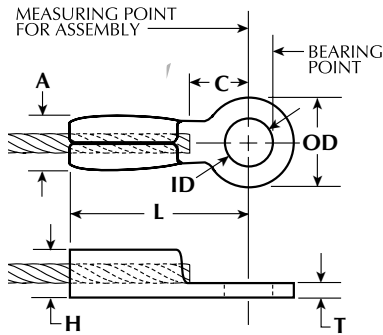

** CONFIGURATION FOR 10-698 AND 10-705 SHOWN WITH OPTIONAL CLIP 81-088

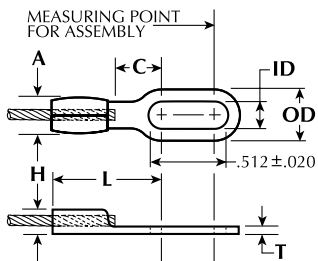

* CONFIGURATION FOR 10-653

PART NO.	CABLE DIA.	ID	OD	T	C MIN.	A REF.	H REF.	L REF.
		$\pm .010 / 0.25$ $-.005 / 0.13$ in./ mm	$\pm .020 / 0.51$ in./ mm	$+ .010 / 0.25$ $-.005 / 0.13$ in./ mm				
10/531	1/32/ 0.79	.142/ 3.61	.260/ 6.60	.042/ 1.07	.09	.17	.10	.63
10-581	1/32/ 0.79	.157/ 3.99	.260/ 6.60	.042/ 1.07	.09	.14	.09	.44
10-538	3/64/ 1.19	.125/ 3.18	.320/ 8.13	.046/ 1.17	.14	.19	.11	.73
10-047	3/64/ 1.19	.156/ 3.96	.320/ 8.13	.046/ 1.17	.14	.19	.11	.73
10-710	3/64/ 1.19	.165/ 4.19	.320/ 8.13	.046/ 1.17	.14	.19	.11	.73
10-653*	3/64/ 1.19	.165/ 4.19	.314/ 7.98	.048/ 1.22	.14	.23	.13	.71
10-556	3/64/ 1.19	.190/ 4.83	.320/ 8.13	.046/ 1.17	.14	.19	.11	.73
10-669	3/64/ 1.19	.167/ 4.24	.320/ 8.13	.046/ 1.17	.14	.19	.11	.73
10-063	1/16/ 1.59	.190/ 4.83	.420/ 10.67	.062/ 1.57	.29	.24	.16	.99
10-633	1/16/ 1.59	.220/ 5.59	.420/ 10.67	.062/ 1.57	.43	.26	.16	.96
10-634	1/16/ 1.59	.193/ 4.90	.320/ 8.13	.046/ 1.17	.33	.19	.11	.70
10-544	1/16/ 1.59	.235/ 5.97	.460/ 11.68	.062/ 1.57	.17	.26	.16	.82
10-553	1/16/ 1.59	.250/ 6.35	.460/ 11.68	.062/ 1.57	.17	.26	.16	.82
10-708	1/16/ 1.59	.261/ 6.63	.433/ 11.00	.036/ 0.91	.34	.19	.11	.89
10-532	1/16/ 1.59	.262/ 6.65	.460/ 11.68	.062/ 1.57	.17	.26	.16	.52
10-548	1/16/ 1.59	.262/ 6.65	.460/ 11.68	.062/ 1.57	.17	.26	.16	.82
10-589	1/16/ 1.59	.255/ 6.48	.420/ 10.67	.062/ 1.57	.29	.24	.16	.99
10-772	1/16/ 1.59	.165/ 4.19	.420/ 10.67	.060/ 1.52	.29	.24	.16	.99
10-709	5/64/ 1.98	.241/ 6.12	.394/ 10.01	.036/ 0.91	.34	.20	.14	.89
10-094	3/32/ 2.38	.255/ 6.48	.500/ 12.70	.093/ 2.36	.41	.34	.26	1.49
10-576	3/32/ 2.38	.312/ 7.92	.500/ 12.70	.093/ 2.36	.41	.34	.26	1.49
10-125	1/8/ 3.18	.255/ 6.48	.674/ 17.12	.125/ 3.18	.62	.44	.33	1.90
10-584	1/8/ 3.18	.281/ 7.14	.674/ 17.12	.125/ 3.18	.62	.44	.33	1.90
10-585	1/8/ 3.18	.343/ 8.71	.674/ 17.12	.125/ 3.18	.62	.44	.33	1.90
10-698**	1/8/ 3.18	.343/ 8.71	.874/ 22.20	.120/ 3.05	.64	.44	.33	1.90
10-668	1/8/ 3.18	.375/ 9.53	.674/ 17.12	.125/ 3.18	.62	.44	.33	1.90
10-667	5/32/ 3.97	.343/ 8.71	.745/ 18.92	.132/ 3.35	.47	.50	.36	1.77
10-630	5/32/ 3.97	.374/ 9.50	.745/ 18.92	.132/ 3.35	.47	.50	.36	1.77
10-628	5/32/ 3.97	.558/ 14.17	1.07/ 27.18	.162/ 4.11	.67	.53	.42	1.76
10-663	3/16/ 4.75	.558/ 14.17	1.07/ 27.18	.162/ 4.11	.67	.59	.45	2.10
10-705**	3/16/ 4.75	.348/ 8.83	1.00/ 25.40	.162/ 4.11	1.05	.56	.45	2.42
10-706	3/16/ 4.75	.591/ 15.00	1.07/ 27.18	.162/ 4.11	.19	.56	.45	2.

NOTE: Dimensions shown are "after swage" of fittings applied to cable.



CMA 20 SERIES THREADED TERMINAL

PART NO.	CABLE DIA. in./mm	H ±.010/ .025 in./mm	L REF.	B MIN.	THREAD
20-036	3/64/ 1.19	.105/ 2.6	1.00	.48	5-40
20-659	1/32/ 0.79	.132/ 3.35	1.50	.94	8-32
20-716	3/64/ 1.19	.135/ 3.43	1.57	1.07	M4x0.7
20-047	3/64/ 1.19	.162/ 4.10	1.00	.38	10-24
20-611	3/64/ 1.19	.155/ 3.94	1.18	.47	M4x0.7
20-782	3/64/ 1.19	.105/ 2.67	1.25	.68	M3x0.5
20-722	3/64/ 1.19	.165/ 4.19	1.25	.75	10-24
20-645	1/16/ 1.59	.132/ 3.35	1.52	.75	8-32
20-063	1/16/ 1.59	.162/ 4.10	1.08	.50	10-24
20-619	1/16/ 1.59	.218/ 5.54	1.10	.42	1/4-20
20-699	5/64/ 1.98	.132/ 3.25	1.62	1.13	M4x0.7
20-094	3/32/ 2.38	.218/ 5.54	1.38	.75	1/4-20
20-692	3/32/ 2.38	.218/ 5.54	2.06	1.50	1/4-20
20-799	3/32/ 2.38	.218/ 5.54	2.20	1.37	M6x1.0
20-125	1/8/ 3.18	.218/ 5.54	1.44	.60	1/4-20
20-675	1/8/ 3.18	.270/ 6.86	2.80	1.72	5/16-18
20-705	1/8/ 3.18	.218/ 5.54	1.50	.97	1/4-28
20-800	5/32/ 3.97	.218/ 5.54	4.10	2.85	1/4-20
20-188	3/16/ 4.76	.325/ 8.26	2.36	1.25	3/8-16
20-582	3/16/ 4.76	.325/ 8.26	2.30	1.11	5/16-18
20-644	3/16/ 4.76	.375/ 9.53	3.60	2.10	7/16-20

NOTE: Dimensions shown are "after swage" of fittings applied to cable.

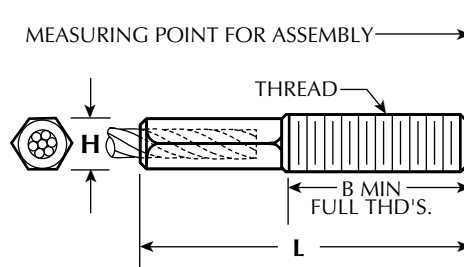



CMA 40 SERIES BALL

PART NO.	CABLE DIA.	DIA.	L REF.
	in./mm	$\pm.010/0.25$ in./mm	
40-027	1/32/.079	.125/3.18	.12
40-501	1/32/0.79	.156/3.96	.15
40-505	3/64/1.19	.125*/3.18	.12
40-556	3/64/1.19	.188*/4.78	.17
40-513	3/64/1.19	.188/4.78	.15
40-544	3/64/1.19	.156/3.96	.15
40-512	3/64/1.19	.250/6.35	.22
40-063	1/16/1.59	.188*/4.78	.14
40-523	1/16/1.59	.250/6.35	.22
40-094	3/32/2.38	.250/6.35	.21
40-125	1/8/3.18	.312/7.92	.23
40-156	5/32/3.97	.375/9.53	.28
40-188	3/16/4.76	.442/11.23	.36
40-250	1/4/6.35	.567/14.40	.31
40-313	5/16/7.94	.694/17.63	.52
40-375	3/8/9.53	.812/20.62	.62

*Specified tolerance of $\pm.005$ (0.13).

NOTE: Dimensions shown are "after swage" of fittings applied to cable.

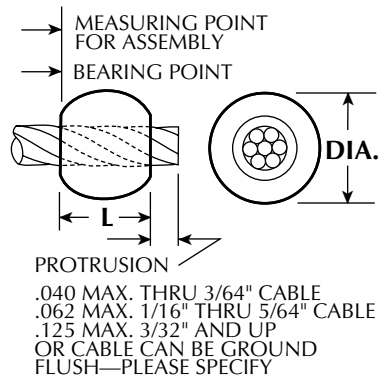



CMA 50 SERIES LOOP

PART NO.	CABLE DIA. in./ mm	DIA. REF.	L. REF.
50-031	1/32/ 0.79	.10	.31
50-047	3/64/ 1.19	.15	.47
50-533	3/64/ 1.19	.18	.20
50-063	1/16/ 1.59	.19	.49
50-094	3/32/ 2.38	.25	.62
50-125	1/8/ 3.18	.35	.82
50-156	5/32/ 3.97	.39	.82
50-188	3/16/ 4.76	.47	1.25
50-250	1/4/ 6.35	.59	1.63
50-313	5/16/ 7.94	.72	1.72

Loop fittings available in aluminum or copper, special finishes upon request.
Please specify PIN diameter and S dimension.

Note: Dimensions shown are "after swage of fittings applied to cable.

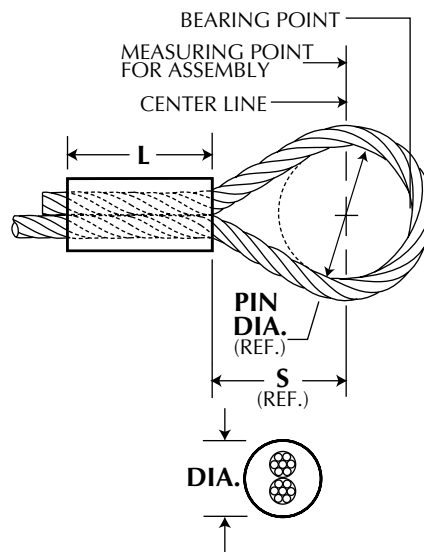

NOTE: PLEASE SPECIFY PIN DIA.
AND S DIMENSION



CMA 100 SERIES THIMBLE

Part No.	Part No.	TO FIT CABLE RANGE		A REF.	B REF.	C REF.	D REF.	E REF.	F REF.
		in./mm	in./mm						
AN 100-01	AN 100-CO1	1/32/0.79	3/64/1.19	.19	1/4	1/8	1/8	.02	3/64
AN 100-03	AN 100-CO3	1/16/1.59	3/32/2.38	.35	43/64	3/16	3/32	.03	5/64
AN 100-04	AN 100-CO4	3/32/2.38	1/8/3.18	.35	45/64	7/32	9/64	.03	5/64
AN 100-05	AN 100-CO5	5/32/3.97	-	.40	51/64	7/32	11/64	.03	7/64
AN 100-06	AN 100-CO6	3/16/4.76	-	.50	1	5/16	13/64	.03	11/64
AN 100-08	AN 100-CO8	7/32/5.36	1/4/6.35	.70	1-13/32	13/32	17/46	.03	11/64
AN 100-10	AN 100-C10	9/32/7.14	5/16/7.94	.90	1-51/64	7/16	21/64	.04	7/32
AN 100-12	AN 100-C12	3/8/9.53	-	1.00	2	5/8	25/64	.06	17/64

Use with 50 Series Loop fittings for greater strength and wear resistance.

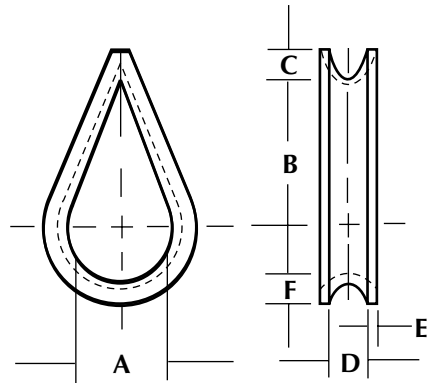



CMA 60 SERIES HEX PLUG

PART NO.	CABLE DIA. in./mm	H ±.010/ 0.25 in./mm	L REF.
		60-527	1/32/ 0.79
60-582	1/32/ 0.79	.140/ 3.56	.16
60-684	1/32/ 0.79	.142/ 3.60	.18
60-576	3/64/ 1.19	.105/ 2.67	.18
60-036	3/64/ 1.19	.130/ 3.30	.30
60-694*	3/64/ 1.19	.162/ 4.10	.25
60-621	3/64/ 1.19	.142/ 3.60	.15
60-752*	3/64/ 1.19	.108/ 2.70	.32
60-700*	1/16/ 1.59	.162/ 4.10	.23
60-509	1/16/ 1.59	.162/ 4.10	.25
60-722*	1/16/ 1.59	.162/ 4.10	.50
60-723	1/16/ 1.59	.162/ 4.10	.50
60-716	5/64/ 1.98	.162/ 4.10	.24
60-615	1/8/ 3.18	.325/ 8.26	.63
60-683	1/8/ 3.18	.345/ 8.76	.51
60-743	5/32/ 3.97	.433/ 11.00	.69
60-698	3/16/ 4.76	.345/ 8.76	.50

*Actual configuration is Ball End Hex Plug.

NOTE: Dimensions shown are "after swage" of fittings applied to cable.

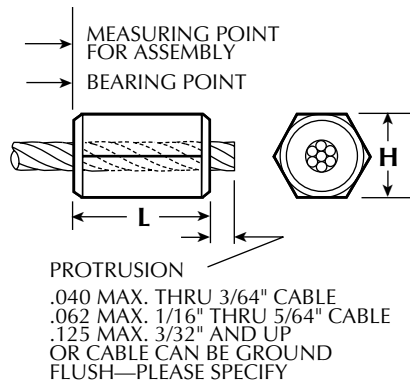



CMA 60 SERIES ROUND PLUG

PART NO.	CABLE DIA. in./mm	H ±.010/ .025 in./mm	L REF.
		60-770	1/16/ 1.59
60-063	1/16/ 1.59	.250/ 6.35	.41
60-094	3/32/ 2.38	.312/ 7.92	.50
60-689	1/8/ 3.18	.290/ 7.37	.52
60-125	1/8/ 3.18	.375/ 9.53	.66
60-156	5/32/ 3.97	.438/ 11.13	.68
60-188	3/16/ 4.76	.500/ 12.70	.75
60-603	1/4/ 6.35	.500/ 12.70	1.15
60-313	5/16/ 7.94	.750/ 19.05	1.25
60-375	3/8/ 9.53	.875/ 22.23	1.56

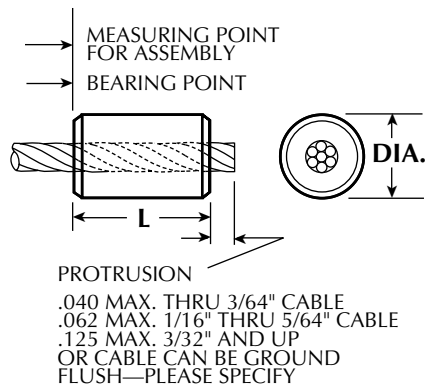



CMA 65 SERIES SWAGED BARREL

PART NO.	CABLE DIA.	A REF.	L	DIA.
	in./mm		+ .010/ .025 in./mm	+ .010/ .025 in./mm
65-004	.047/ 1.19	-	.200/ 5.08	.188/ 4.78
65-005	.063/ 1.60	-	.350/ 8.89	.188/ 4.78
65-006*	.078/ 1.98	.09	.268/ 6.81	.188/ 4.78

* Offset Swaged Barrel

Holding strength varies with fitting size and cable selections.
Consult CMA Engineering department for further information.

Note: Dimensions shown are "after swage" of fittings applied to cable.

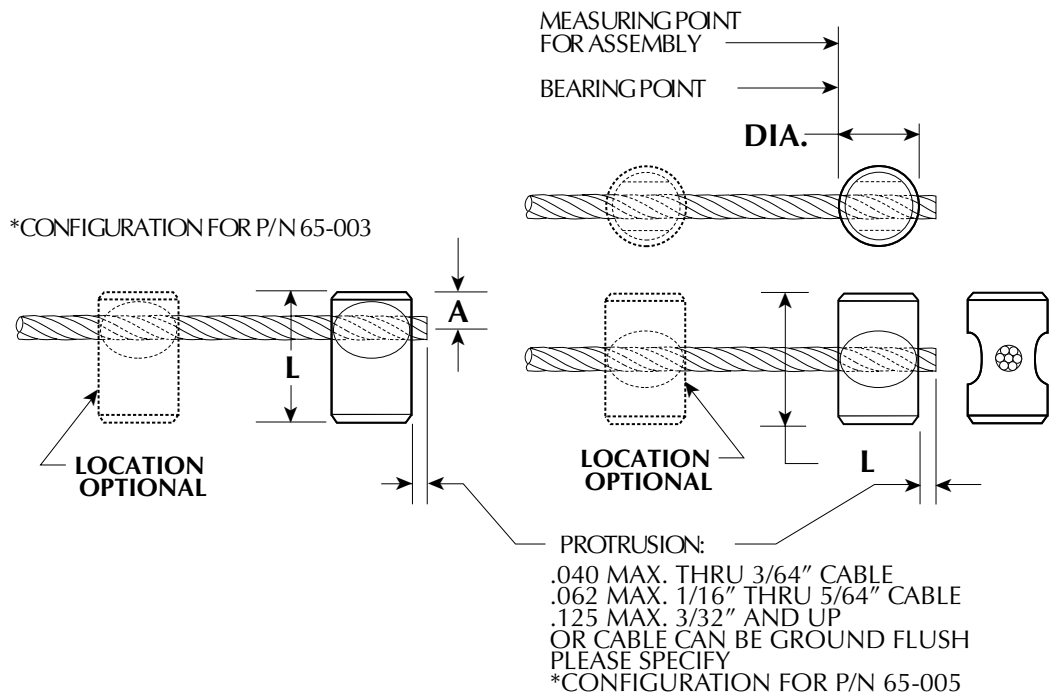



CMA 70 SERIES BALL AND SHANK

PART NO.	CABLE DIA.	A DIA.	B DIA.	C REF.
	in./ mm	+ .010/ .025 in./ mm	+ .010/ .025 in./ mm	
70-047	3.64/ 1.19	.112/ 2.84	.190/ 4.83	.16
70-063	1/16/ 1.59	.112/ 2.84	.190/ 4.83	.16
70-094	3/32/ 2.38	.143/ 3.63	.253/ 6.43	.23
70-125	1/8/ 3.18	.190/ 4.83	.315/ 8.00	.31
70-156	5/32/ 3.97	.222/ 5.64	.379/ 9.63	.39
70-188	3/16/ 4.76	.255/ 6.48	.442/ 11.23	.47
70-250	1/4/ 6.35	.348/ 8.84	.567/ 14.40	.63
70-281	9/32/ 7.14	.382/ 9.70	.632/ 16.05	.75
70-313	5/16/ 7.94	.413/ 10.49	.694/ 17.63	.81

Note: Dimensions shown are "after swage" of fittings applied to cable.

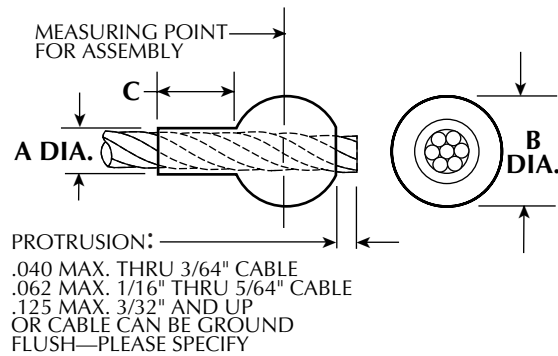



CMA 86 SERIES CLEVIS

PART NO.	A REF.	B REF.	ID REF. + .010/ 0.25 In./ mm	E REF.	F REF. + .015/ 0.38 in./ mm	G. DIA. in./ mm	H REF.	T REF.	STYLE	RECOMMENDED CABLE in./ mm	FITTING
86-001	1.63	-	.531/ 13.49	1.25	.58	.406/ 10.31	-	.19	1	1/4/ 6.35	70-250
86-002	1.75	-	.656/ 16.66	1.25	.82	.469/ 11.91	-	.19	1	5/16/ 7.94	70-313
86-003	1.12	-	.315/ 8.00	.75	.48	.268/ 6.81	-	.13	2	9/16/ 4.76	70-188
86-004	1.44	-	.315/ 8.00	.75	.47	.268/ 6.81	-	.13	2	3/16/ 4.76	70-188
86-005	2.40	1.00	.195/ 4.95	.75	.28	.195/ 4.95	.51	.13	3	3/32/ 2.38	70-094
86-006	2.40	1.00	.320/ 8.13	.75	.28	.281/ 7.14	.51	.13	3	3/16/ 4.76	70-188

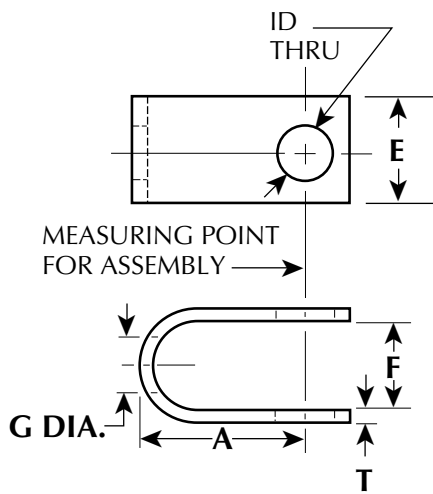

STYLE #1

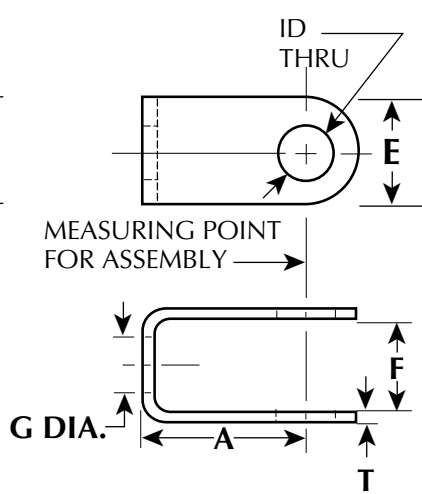

STYLE #2

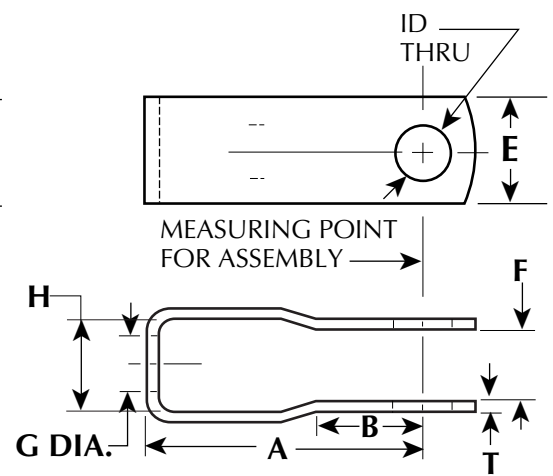

STYLE #3



CMA 67 SERIES DIE CAST BARREL

PART NO.	CABLE DIA.	L REF.	W	DIA.
	in./mm		+0.10/ .025 in./mm	+ .005/ 0.13 in./mm
67-509	.045/ 1.14	-	.395/ 10.03	.215/ 5.46
67-513**	.045/ 1.14	-	.290/ 7.37	.141/ 3.58
67-516	.045/ 1.14	-	.295/ 7.49	.197/ 5.00
67-511	1/16/ 1.59	-	.443/ 11.25	.173/ 4.39
67-512	1/16/ 1.59	-	.316/ 8.03	.228/ 5.79
67-507*	1/8/ 3.18	.33	.500/ 12.70	.375/ 9.53

Note: Cable end must be "upset" to maintain holding strength.

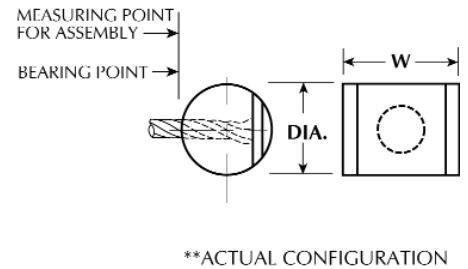
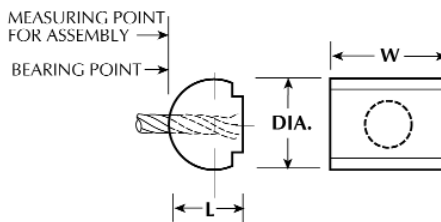
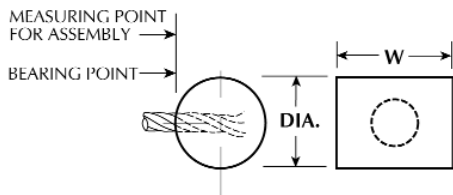

CMA 47 SERIES DIE CAST BALL/PLUG

PART NO.	CABLE DIA.	DIA	L REF.
	in./mm	+ .010/ 0.25 in./mm	
47-505	3/64/ 1.19	.188/ 4.78	-
47-500	1/16/ 1.59	.188/ 4.78	-
47-694	3/64/ 1.19	.170/ 4.32	.250/ 6.35

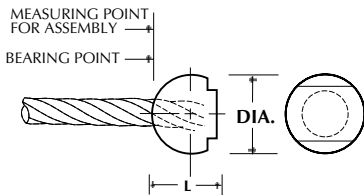

Note: Cable end must be "upset" to maintain holding strength.



CMA 87 SERIES DIE CAST Z FITTING

PART NO.	CABLE DIA. in./mm	DIA.	A	B	L
		$\pm .003$ in./mm	$\pm .005$ in./mm	$\pm .005$ in./mm	REF.
87-504	3/64/ 1.19	.143/ 3.6	.250/ 6.35	.312/ 7.92	.763
87-505	3/64/ 1.19	.143/ 3.6	.260/ 6.6	.200/ 5.0	.773
87-507	1/16/ 1.59	.165/ 4.2	.197/ 5.0	.165/ 4.2	.792

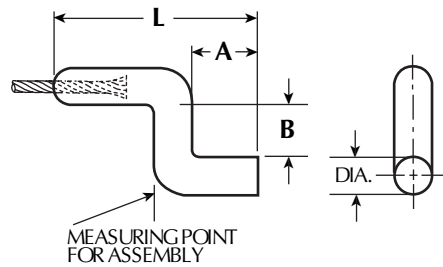



CMA 88 SERIES SWAGED Z FITTING

PART NO.	CABLE DIA.	DIA.	A	B	H	L Ref.
	in./mm	$\pm .003/0.12$ in./mm	$\pm .020/0.50$ in./mm	$\pm .010/0.25$ in./mm	$\pm .005/0.12$ in./mm	
88-011	1/32/0.79	.140/3.55	.340/8.63	.200/5.08	.120/3.04	1.00/25.4
88-002	3/64/1.14	.140/3.55	.340/8.63	.200/5.08	.120/3.04	1.00/25.4
88-007	3/64/1.14	.156/3.96	.164/4.2	.184/4.7	.142/3.6	.690/17.5
88-008	3/64/1.14	.140/3.55	.250/6.4	.200/5.08	.120/3.04	.910/23.1
88-003	1/16/1.6	.140/3.55	.340/8.63	.200/5.08	.120/3.04	1.00/25.4
88-012	1/16/1.6	.120/3.04	.218/5.5	.167/4.2	.105/2.67	.758/19.3
88-013	1/8/3.18	.187/4.76	.187/4.65	.157/4.0	.156/3.96	1.00/25.4

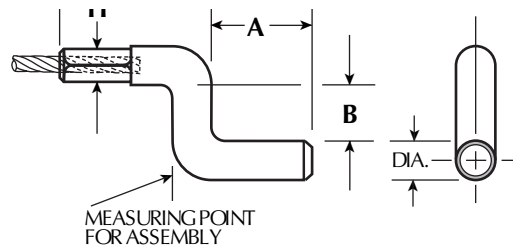



SOLID CORE WIRE

CORE WIRE PART NO.	OD $\pm .001 / 0.03$ in./mm
Type 302 S/S Spring Wire	
CC-521030	.030 / 0.76
CC-521032	.032 / 0.81
CC-521041	.041 / 1.04
CC-521047	.047 / 1.19
CC-521054	.054 / 1.37
CC-521062	.062 / 1.57
CC-521072	.072 / 1.83
CC-521075	.075 / 1.90
CC-521088	.088 / 2.24
Hard Drawn Galvanized Spring Wire	
CC-591047	.047 / 1.19
CC-591054	.054 / 1.37
CC-591062	.062 / 1.57
CC-591072	.072 / 1.83

Note: Additional diameters, material specifications and finishes are available.
Material listed is normally in stock subject to prior orders.
Please contact CMA Sales and Engineering departments for further information.



WIRE CORE TERMINATIONS

NO BEND

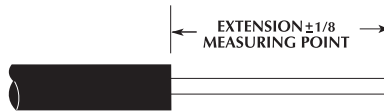

"L" BEND

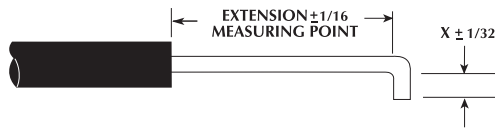

"Z" BEND

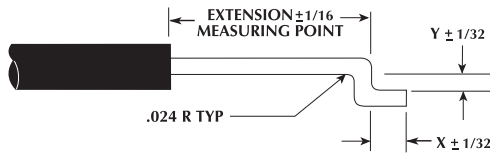

OFFSET LOOP

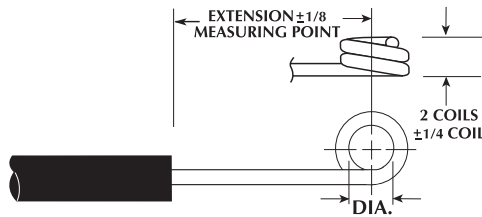

CENTER LOOP

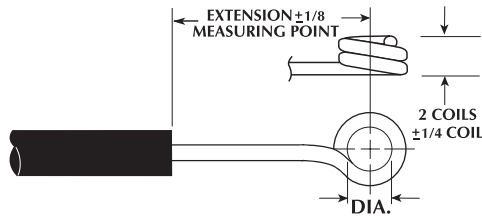

- Note: 1. Standard diameter for loops is .156"-.205." Other loop diameters can be supplied. Loop ends are present, are available only with core diameters of .047" and .054".
2. For "Z" bend standard, X is .170" and Y is .159". Other X and Y dimensions can be supplied. "Z" bend ends, at present, are available with a core diameter of .030".



CYCLE FLEX MINIATURE CABLE SPECIFICATIONS

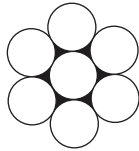

1 x 7

Cycle Flex Part No. Bare	Nominal Bare Dia. in./mm	Cycle-Flex Part No. Coated w/ PC-100	Nominal Coated Dia. in./mm	Min. Breaking Strength Lb./Kg.	Min. Recommended Pulley Dia. in./mm	"C" Rating	"F" Rating	"EA" Value x10 ³	Weight per M Ft. Lb./Kg.
CF-0612S	.006/ .15	CF-0614S	.010/ .25	5/ 2.3	.80/ 20.32	.022	43	.47	.10/ .045
CF-0912S	.009/ .23	CF-0914S	.013/ .33	13/ 5.9	1.20/ 30.48	.049	65	1.06	.22/ .10
CF-1212S	.012/ .30	CF-1214S	.016/ .41	25/ 11.3	1.60/ 40.64	.088	86	1.89	.48/ .22
CF-1812S	.018/ .46	CF-1814S	.024/ .61	40/ 18.1	2.40/ 60.96	.198	129	4.26	1.07/ .49
CF-2412S	.024/ .61	CF-2414S	.030/ .76	85/ 38.6	3.20/ 81.28	.352	172	7.56	1.78/ .81
CF-2712S	.027/ .69	CF-2714S	.034/ .86	125/ 56.7	3.60/ 91.44	.445	194	9.57	2.28/ 1.03
CF3112S	.031/ .79	CF-3114S	.039/ .99	125/ 56.7	4.13/ 104.90	.566	218	12.17	2.96/ 1.34

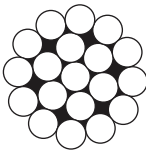

1 x 19

CF-1032S*	.010/ .25	CF-1034S*	.014/ .36	19/ 8.6	.80/ 20.32	.060	42	1.25	.38/ .172
CF-1532S*	.015/ .38	CF-1534S*	.021/ .53	30/ 13.6	1.20/ 30.48	.134	63	2.82	.79/ .36
CF-2632S*	.026/ .66	CF-2634S*	.033/ .84	80/ 36.4	2.08/ 52.83	.382	106	8.02	1.74/ .79

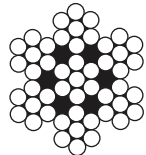

7 x 7

CF-0952S	.009/ .23	CF-0954S	.013/ .33	7.5/ 3.4	.41/ 10.41	.038	19	.73	.26/ .12
CF-1452S	.014/ .36	CF-1454S	.018/ .46	20/ 9.07	.64/ 16.26	.099	30	1.88	.51/ .23
CF-1852S	.018/ .46	CF-1854S	.024/ .61	40/ 18.1	.80/ 20.32	.154	38	2.93	.86/ .39
CF-2352S*	.023/ .58	CF-2354S*	.030/ .76	60/ 27.3	1.00/ 25.40	.241	48	4.58	1.35/ .613
CF-2752S*	.027/ .69	CF-2754S*	.034/ .86	90/ 40.8	1.20/ 30.48	.346	57	6.58	1.64/ .75
CF-3252S	.032/ .81	CF-3254S	.040/ 1.02	115/ 52.1	1.40/ 35.56	.418	62	7.94	2.00/ .91
CF-3752S	.037/ .94	CF-3754S	.047/ 1.19	160/ 72.6	1.60/ 40.64	.616	76	11.70	2.99/ 1.36

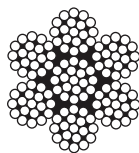

7 x 19

CF-1572S	.015/ .38	CF-1574S	.021/ .53	35/ 15.9	.40/ 10.16	.104	17	1.78	.71/ .32
CF-1872S	.018/ .46	CF-1874S	.024/ .61	40/ 18.1	.48/ 12.19	.150	20	2.56	.93/ .42
CF-2472S*	.024/ .61	CF-2474S*	.030/ .76	70/ 31.8	.64/ 16.26	.267	27	4.55	1.45/ .65
CF-3072S*	.030/ .76	CF-3074S*	.037/ .94	120/ 54.4	.80/ 20.32	.418	34	7.10	1.98/ .90
CF-3872S*	.038/ .97	CF-3874S*	.048/ 1.22	175/ 79.5	1.00/ 25.40	.653	43	11.10	2.71/ 1.23
CF-4572S*	.045/ 1.14	CF-4574S*	.062/ 1.57	225/ 102.2	1.20/ 30.48	.940	51	15.98	4.6/ 2.09

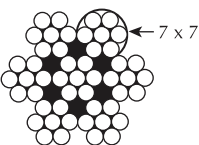

7 x 7 x 7

CF-2782S	.027/ .69	CF-2784S	.034/ .86	80/ 36.4	.40/ 10.16	.269	16	4.31	1.70/ .77
CF-4482S*	.044/ 1.12	CF-4484S*	.053/ 1.35	150/ 68.0	.65/ 16.51	.690	26	11.04	2.67/ 1.21

Note: Cycle-Flex Cable normally available in stock as pre-stretched.

- NOTE:** 1. Standard tolerances for all bare and coated diameters upto and including CF-3874S is ± 0.002 " (± 0.05 mm). CF-4482S thru CF-4574S is ± 0.004 " (± 0.10 mm).
2. Most Cycle-Flex cable can be ordered as pre-stretched. To specify pre-stretched cables add the suffix "PS" to the Cycle-flex part number.



CYCLE-FLEX™ 10 SERIES EYE

PART NO.	CABLE DIA. 1	CABLE DIA. 2	ID + .010/.025 - .005/.013	OD ± .020/.051	T + .010/.025 - .005/.013	C MIN.	A REF.	H REF.	L REF.
	in./mm	in./mm	in./mm	in./mm	in./mm				
10-535	.018/0.46	.032/0.81	.064/1.63	.186/4.72	.042/1.07	.09	.14	.09	.44
10-517	.018/0.46	.032/0.81	.125/3.18	.186/4.72	.042/1.07	.09	.14	.09	.44
10-703	.018/0.46	.032/0.81	.135/3.43	.186/4.72	.042/1.07	.16	.14	.10	.41
10-027	.018/0.46	.032/0.81	.142/3.61	.260/6.60	.042/1.07	.09	.14	.09	.44
10-581	.018/0.46	.032/0.81	.157/3.99	.260/6.60	.042/1.07	.09	.14	.09	.44
10-611	.018/0.46	.032/0.81	.125/3.18	.260/6.60	.042/1.07	.09	.14	.09	.44
10-766	.018/0.46	.032/0.81	.088/2.2	.260/6.60	.042/1.07	.09	.14	.09	.44
10-598	.018/0.46	.032/0.81	.198/5.03	.260/6.60	.042/1.07	.16	.14	.10	.41
10-556	.032/0.81	.045/1.14	.190/4.8	.320/8.1	.046/1.17	.14	.19	.11	.73
10-669	.032/0.81	.045/1.14	.167/4.2	.320/8.1	.046/1.17	.14	.19	.11	.73
10-531	.032/0.81	.045/1.14	.142/3.61	.260/6.60	.042/1.07	.09	.17	.10	.63
10-533	.037/0.94	.038/0.97	.142/3.61	.260/6.60	.042/1.07	.09	.17	.10	.44
10-683	.037/0.94	.045/1.14	.171/4.34	.280/7.11	.042/1.07	.09	.17	.10	.63
10-047	.045/1.14	-	.156/3.96	.320/8.13	.046/1.17	.14	.19	.11	.73
10-625	.045/1.14	-	.187/4.7	.260/6.60	.042/1.07	.09	.14	.09	.44
10-626	.045/1.14	-	.156/3.96	.260/6.60	.042/1.07	.09	.14	.09	.44

Note: Dimensions shown are "after swage" of fittings applied to cable.

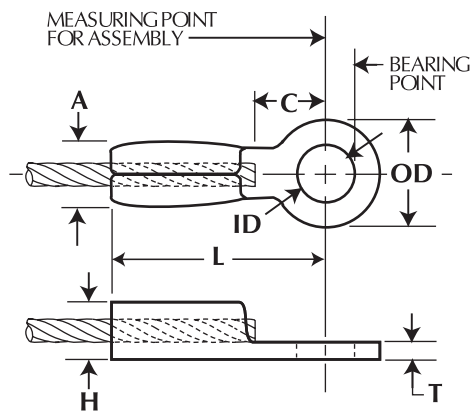



CYCLE-FLEX™ 20 SERIES THREADED TERMINAL

PART NO.	CABLE DIA. 1 in./mm	CABLE DIA. 2 in./mm	H ±.010/0.25 in./mm	L REF.	B MIN.	THREAD
20-018	.018/ 0.46	.024/ 0.61	.105/ 2.67	1.00	.48	5-40
20-027	.023/ 0.58	.034/ 0.86	.105/ 2.67	1.00	.48	5-40
20-650	.027/ 0.69	.034/ 0.86	.065/ 1.65	.80	.41	2-64
20-542	.027/ 0.69	.037/ 0.94	.105/ 2.67	1.28	.70	4-40
20-718	.027/ 0.69	.037/ 0.94	.130/ 3.30	1.35	.86	M4x0.7
20-036	.036/ 0.91	.048/ 1.22	.105/ 2.67	1.00	.48	5-40
20-659	.027/ 0.69	.037/ 0.94	.132/ 3.35	1.50	.94	8-32
20-047	.045/ 1.14	.048/ 1.22	.162/ 4.10	1.00	.38	10-24
20-611	.045/ 1.14	.048/ 1.22	.155/ 3.94	1.18	.47	M4x0.7
20-722	.045/ 1.14	.048/ 1.22	.165/ 4.19	1.25	.75	10-24
20-782	.045/ 1.14	.048/ 1.22	.105/ 2.67	1.25	.68	M3x0.5

- NOTES:** 1. Dimensions shown are "after swage" of fittings applied to cable.
2. Fittings have been designed to fit the largest diameter cable in the range. When used on smaller diameter cable, lower tensile strength will result. Consult CMA engineering for further information.

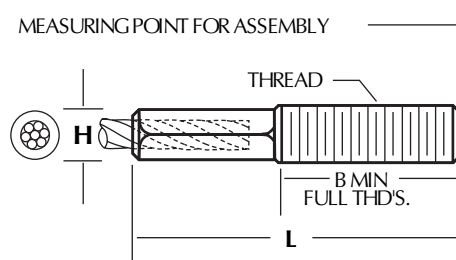



CYCLE-FLEX™ 40 SERIES BALL

PART NO.	CABLE DIA. DIA. 1 in./mm	CABLE DIA. DIA. 2 in./mm	DIA. ±.010/0.13 in./mm	L Ref.
40-578	.014/ 0.36	.018/ 0.46	.063/ 1.60	.07
40-506	.014/ 0.36	.018/ 0.46	.093/ 2.36	.09
40-018	.014/ 0.36	.018/ 0.46	.125/ 3.18	.12
40-571	.018/ 0.46	.024/ 0.61	.156/ 3.96	.15
40-027	.023/ 0.58	.027/ 0.69	.125/ 3.18	.11
40-501	.023/ 0.58	.027/ 0.69	.156/ 3.96	.16
40-542	.023/ 0.58	.032/ 0.81	.188/ 4.78	.18
40-574	.024/ 0.61	.030/ 0.76	.156/ 3.96	.14
40-550	.027/ 0.69	.030/ 0.76	.093/ 2.36	.09
40-525	.030/ 0.76	.032/ 0.81	.125/ 3.18	.11
40-548	.030/ 0.76	.032/ 0.81	.156/ 3.96	.15
40-503	.036/ 0.91	.038/ 0.97	.125/ 3.18	.12
40-537	.036/ 0.91	.038/ 0.97	.250/ 6.35	.23
40-599	.036/ 0.91	.038/ 0.97	.118/ 4.78	.12
40-505	.045/ 1.14	—	.125/ 3.18	.12
40-556	.045/ 1.14	—	.188/ 4.78	.17
40-512	.045/ 1.14	—	.250*/ 6.35	.22
40-513	.045/ 1.14	—	.188/ 4.78	.15
40-544	.045/ 1.14	—	.156/ 3.96	.15

- NOTES:** 1. Dimensions shown are "after swage" of fittings applied to cable.
2. Fittings have been designed to fit the largest diameter cable in the range. When used on smaller diameter cable, lower tensile strength will result. Consult CMA engineering for further information.

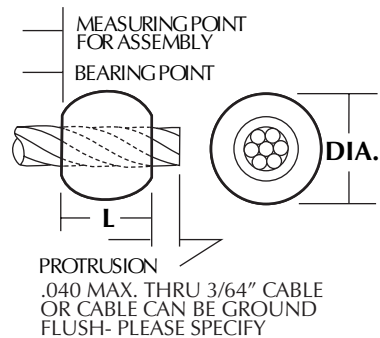



CYCLE-FLEX™ 50 SERIES LOOP

	CABLE DIA. DIA. 1 in./mm	H ±.010/ 0.25 in./mm	L Ref.	H Cross Section
50-534*	.014/ 0.36 .027/ 0.69	.105/ 2.67	.17	Oval
50-014	.018/ 0.46	.063/ 1.60	.23	Hex
50-018	.021/ 0.53 .024/ .061	.070/ 1.78	.24	Hex
50-027	.027/ 0.69 .030/ 0.76	.100/ 2.54	.31	Hex
50-531	.030/ 0.76 .038/ 0.97	.075/ 1.90	.17	Round
50-031	.030/ 0.76 .038/ 0.97	.095/ 2.41	.31	Round
50-047	.045/ 1.14 .048/ 1.22	.145/ 3.68	.47	Round
50-533	.045/ 1.14 .048/ 1.22	.145/ 3.68	.24	Round

Please specify PIN diameter and S dimension.

Note: Dimensions shown are "after swage of fittings applied to cable.

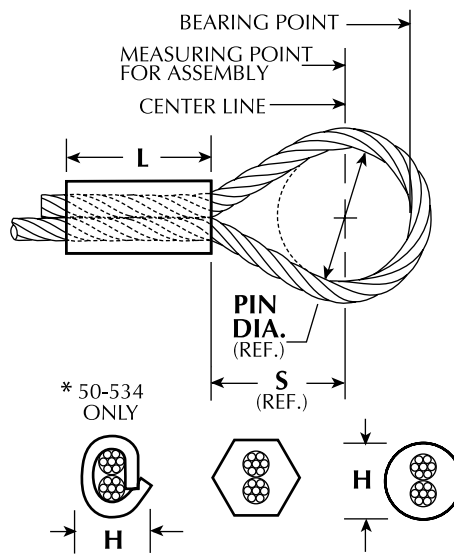

NOTE: PLEASE SPECIFY PIN DIA.
AND S DIMENSION



CYCLE-FLEX™ 40 SERIES HEX BALL

PART NO.	CABLE DIA. DIA. 1 in./mm	H ±.010/ 0.25 in./mm	L Ref.
40-543	.018/ 0.46 .023/ 0.58	.100/ 2.54	.14
40-526	.027/ 0.69 .030/ 0.76	.141/ 3.58	.18
40-527	.027/ 0.69 .030/ 0.76	.203/ 5.16	.25
40-553	.032/ 0.81 .038/ 0.97	.141/ 3.58	.18
40-552	.032/ 0.81 .038/ 0.97	.203/ 5.16	.24

NOTES: Dimensions shown are "after swage" of fittings applied to cable.

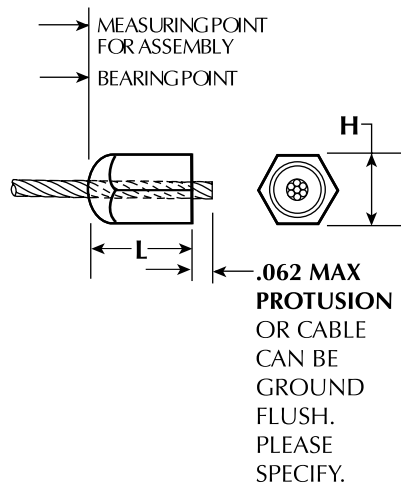



CYCLE-FLEX™ 60 SERIES HEX PLUG

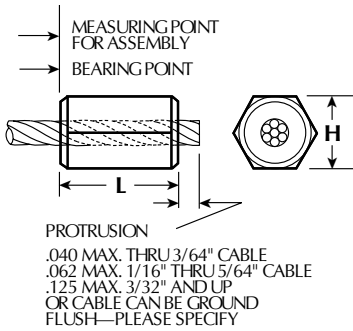

PART NO.	CABLE DIA. 1 in./mm	CABLE DIA. 2 in./mm	H ±.010/0.25 in./mm	L REF.
60-528	.010/ 0.25	.024/ 0.61	.105/ 2.67	.21
60-018	.018/ 0.46	.024/ 0.61	.130/ 3.30	.30
60-582	.023/ 0.58	.030/ 0.76	.140/ 3.56	.16
60-716	.023/ 0.58	.033/ 0.84	.187/ 4.76	.21
60-527	.027/ 0.69	.036/ 0.91	.125/ 3.18	.31
60-027	.027/ 0.69	.036/ 0.91	.130/ 3.30	.30
60-684	.027/ 0.69	.036/ 0.91	.083/ 2.10	.18
60-576	.036/ 0.91	.048/ 1.22	.105/ 2.67	.18
60-036	.037/ 0.94	.048/ 1.22	.130/ 3.30	.30
60-621	.037/ 0.94	.048/ 1.22	.142/ 3.60	.15

- NOTES:** 1. Dimensions shown are "after swage" of fittings applied to cable.
2. Fittings have been designed to fit the largest diameter cable in the range. When used on smaller diameter cable, lower tensile strength will result. Consult CMA engineering for further information.

CYCLE-FLEX™ 60 SERIES RADIUS PLUG

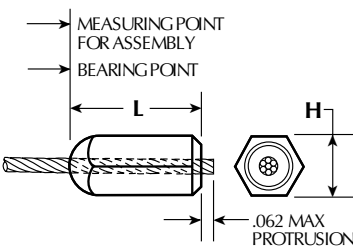

PART NO.	CABLE DIA. 1 in./mm	CABLE DIA. 2 in./mm	H ±.010/ 0.25 in./mm	L REF.
60-608	.010/ 0.25	.027/ 0.69	.125/ 3.18	.40
60-622	.018/ 0.46	.024/ 0.61	.048/ 1.22	.08
60-606	.030/ 0.76	.037/ 0.94	.105/ 2.67	.25
60-609	.030/ 0.76	.037/ 0.94	.130/ 3.30	.41
60-752	.038/ 0.97	.045/ 1.14	.108/ 2.70	.32
60-610	.038/ 0.97	.048/ 1.22	.130/ 3.30	.42
60-611	.047/ 1.19	.062/ 1.57	.130/ 3.30	.42

- NOTES:** 1. Dimensions shown are "after swage" of fittings applied to cable.
2. Fittings have been designed to fit the largest diameter cable in the range. When used on smaller diameter cable, lower tensile strength will result. Consult CMA engineering for further information.



CYCLE-FLEX™ 65 SERIES SWAGED BARREL

PART NO.	CABLE DIA.	A REF.	L	DIA.
	in./mm		±.015/ 0.38 in./mm	±.010/ 0.25 in./mm
65-001	.018/ 0.46		.065/ 1.65	.064/ 1.63
65-002	.031/ 0.79		.250/ 6.35	.116/ 2.95
65-003*	.037/ 0.94	.09	.250/ 6.35	.155/ 3.94
65-004	.045/ 1.14		.200/ 5.08	.188/ 4.78

* Offset swaged barrel

- NOTES:** 1. Dimensions shown are "after swage" of fittings applied to cable.
2. Fittings have been designed to fit the largest diameter cable in the range. When used on smaller diameter cable, lower tensile strength will result. Consult CMA engineering for further information.

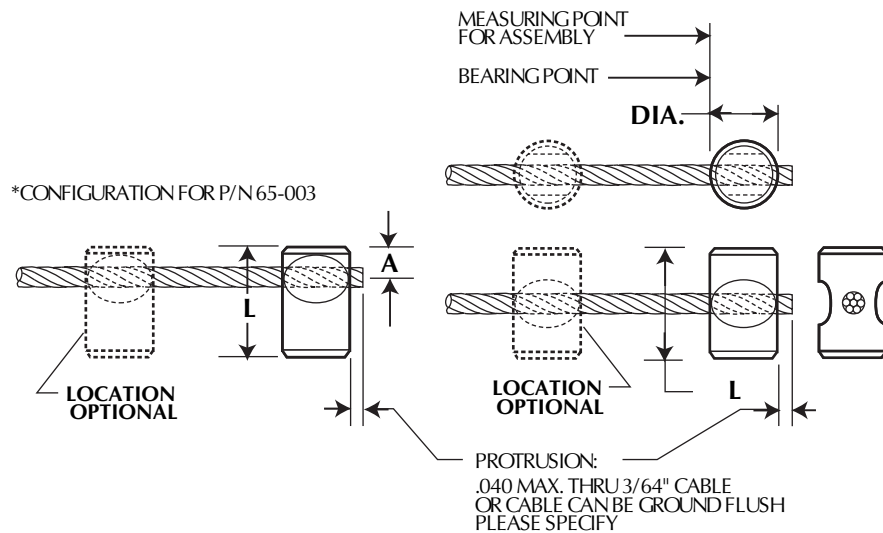



CYCLE-FLEX™ 80 SERIES TURNBUCKLE

PART NO.	Max. Cable Dia. in./mm	Length -.015/ 0.13 in./mm	H ±.005/ 0.13 in./mm	Thread	Min. Full Thd	Dia. Ball Req'd.
80-667	.045/ 1.14	.826/ 20.98	.312/ 7.94	M4x.07	.47	.125
80-754	.045/ 1.14	1.000/ 25.40	.187/ 4.75	5-40	.75	.093
80-755	.045/ 1.14	1.120/ 28.45	.250/ 6.35	8-32	.66	.125
80-756	.045/ 1.14	1.250/ 31.75	.281/ 7.14	10-24	.38	.125
80-290	.047/ 1.19	1.000/ 25.40	.187/ 4.75	M3x0.5	.77	.093

Select mating part from Cycle-Flex 20 Series Threaded Terminals.

- NOTES:** 1. Dimensions shown are "after swage" of fittings applied to cable.
2. Fittings have been designed to fit the largest diameter cable in the range. When used on smaller diameter cable, lower tensile strength will result. Consult CMA engineering for further information.

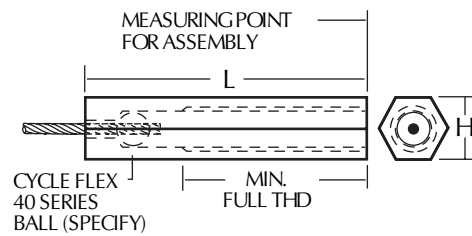



CONDUIT SPECIFICATIONS

PART NO.	ID REF in./mm	LINER MATERIAL	MAX. CABLE DIA PULL-PULL in./mm	MAX. SOLID WIRE PULL-PULL in./mm	OD REF in./mm	COATING MATERIAL
Braided Reinforced						
C002/C006	.063/1.60	ACE	.047/ 1.19	.047/ 1.19	.203/ 5.16	BLK PP/BLK NYL
C003/C010	.077/ 1.96	ACE	.063/ 1.60	.054/ 1.37	.203/ 5.16	BLK PP/BLK NYL
C005	.075/ 1.91	TFE	.063/ 1.60	.054/ 1.37	.233/ 5.92	BLK NYL
C007	.085/ 2.16	ACE	.063/ 1.60	.062/ 1.57	.203/ 5.16	BLK PP
C008	.051/ 1.30	ACE	.038/ 0.97	.036/ 0.91	.135/ 3.43	BLK NYL
C009	.111/ 2.82	ACE	.094/ 2.39	.088/ 2.24	.262/ 6.65	BLK PP
C015	.063/ 1.60	ACE	.047/ 1.19	.047/ 1.19	.170/ 4.32	BLK NYL
C019	.105/ 2.67	ACE	.078/ 1.98	.088/ 2.24	.220/ 5.60	BLK NYL
C023*	.075/ 1.90	ACE	.063/ 1.60	.054/ 1.37	.203/ 5.16	BLK NYL
C024	.077/ 1.96	ACE	.063/ 1.60	.054/ 1.37	.203/ 5.16	BLK PE
C025	.063/ 1.60	ACE	.047/ 1.19	.047/ 1.19	.203/ 5.16	BLK PE
Bowden-Unlined, Bare/Round Wire						
C403	.087/ 2.21	GAL-RD	.063/ 1.60	.062/ 1.57	.195/ 4.95	GAL-RD
C404	.110/ 2.79	GAL-RD	.094/ 2.39	.088/ 2.24	.260/ 6.60	GAL-RD
Bowden-Unlined, Jacketed/Round Wire						
C601	.079/ 2.01	GAL	.063/ 1.60	.062/ 1.57	.235/ 5.97	BLK PVC-RD
C602	.110/ 2.79	GAL	.094/ 2.39	.088/ 2.24	.319/ 8.10	BLK PVC-RD
Bowden-Lined, Jacketed/Flat or Round Wire						
C705	.075/ 1.90	TFE	.063/ 1.60	.054/ 1.37	.217/ 5.50	BLK TPE-FLAT
C706	.080/ 2.03	PE	.063/ 1.60	.062/ 1.57	.203/ 5.16	BLK TPE-FLAT
Long Lay						
C802	.076/ 1.93	PE	.063/ 1.60	.062/ 1.57	.197/ 5.00	BLK PP
C803	.082/ 2.08	PE	.063/ 1.60	.062/ 1.57	.205/ 5.21	BLK PP
C804	.086/ 2.18	PE	.063/ 1.60	.062/ 1.57	.327/ 8.31	BLK PE
C807**	.062/ 1.57	PE	.047/ 1.19	.047/ 1.19	.203/ 5.16	BLK PE
C808	.150/ 3.81	PE	.125/ 3.17	.125/ 3.17	.350/ 8.89	BLK NYL
C810	.091/ 2.31	PE	.078/ 1.98	.075/ 1.90	.250/ 5.95	GRY PP
C811	.109/ 2.77	PE	.102/ 2.59	.094/ 2.39	.325/ 10.64	GRY PP
C812	.091/ 2.31	PE	.078/ 1.98	.075/ 1.90	.325/ 10.64	GRY PP
C813	.109/ 2.77	PE	.102/ 2.59	.094/ 2.39	.290/ 7.37	GRY PP

*Note: Specified with 24 wire braid—all others specified with 12 wire braid.
**Note: This long lay has more flexibility than standard.

Legend

LINER:	WIRE:	JACKET:	COLOR:
ACE — ACETAL	SS — STAINLESS STEEL	PE — POLYETHYLENE	BLK — BLACK
PP — POLYPROPYLENE	GAL — GALVANIZED STEEL	TPE — THERMOPLASTIC ELASTOMER	NL — NATURAL
TFE — TEFLON	RD — ROUND WIRE	PVC — POLYVINYL CHLORIDE	GRY — GRAY
NYL — NYLON	FLAT — FLAT WIRE	NYL — NYLON	

NOTE: Recommended maximum cable and solid wire cores are based on the inside diameter of the conduit. Variations in control installations and mounting may require smaller or larger core diameters for proper function.



CMA Remote Actuation Systems ACTUATORS

CMA 11603 – Lever Actuator



- Compact molded housing with vertical lever for fingertip actuation
- Recessed mounting with two bezel holes
- Easily assembled to CMA standard cable controls. Cable fitting permanently snaps into lever handle.

2:1 Mechanical advantage
9/16" (14.3 mm) travel
Material: ABS/glass filled nylon
Color: Black

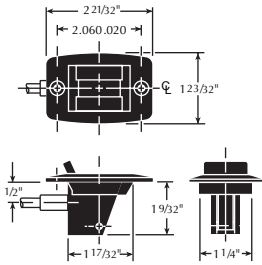

NOTE: For locking gas spring applications, when used with CMA 11602, 11708, or 12030 – specify a gas spring with quick release valve (1mm travel).

Use Molded End No. 1

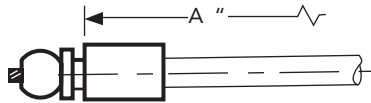

CMA 11764 – Mini Lever Actuator



- Molded compact design for recessed mounting
- Contoured handle for easy two-finger operation
- Optional cable control assembly locations for flexible routing in vertical or horizontal applications
- Integral return spring
- Bezel or pocket mounting holes
- Easily assembled to CMA standard cable controls

Position "A" 3.5:1 Mechanical advantage
.750" (19.0 mm) travel
Position "B" 4:1 Mechanical advantage
.750" (19.0 mm) travel
Material: ABS/polycarbonate
Color: Black

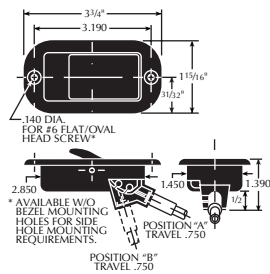

Use Molded End No. 4

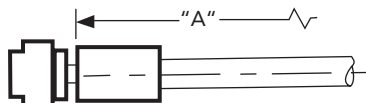



CMA Remote Actuation Systems ACTUATORS

CMA 11605 – Lever Actuator



- Molded design for recessed mounting with larger lever for ease of actuation
- Optional cable control assembly locations for flexible routing in vertical or horizontal installations or two cable controls at the same time.
- Pocket mounting holes and return spring are standard
- Easily assembled to CMA standard cable controls

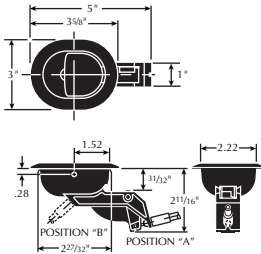

Position "A" 2:1 Mechanical advantage

.840" (21.3 mm) travel

Position "B" 1.7:1 Mechanical advantage

1.300" (33.0 mm) travel

Material: ABS/polycarbonate

Color: Black

Use Molded End No. 3

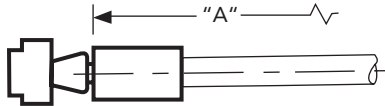

CMA 11604 – Push Button Actuator Round Button/Bezel



- Molded design with large push button for finger or palm actuation
- Adjustable trim ring accommodates mounting surface thickness
- Rear or front surface 4-hole mounting plate
- Integral return spring (optional)
- Supplied assembled to CMA standard cable controls

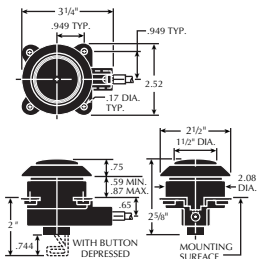

.480" (12.4 mm) travel

Material: Engineering grade thermo-plastics

Color: Black

NOTE: For locking gas spring applications, when used with CMA 11602, 11708, or 12030 – specify a gas spring with quick release valve (1mm travel).

Use Molded End No. 3

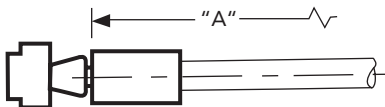



CMA Remote Actuation Systems ACTUATORS

CMA 12074 – Push Button Actuator



- Compact small size for light duty applications only
- Spring loaded mounting bezel accommodates up to .120 thick material

.195" MAX (4.95 mm) travel

1:1 Mechanical advantage

Material: Aluminum/Delrin

Finish: Clear anodize

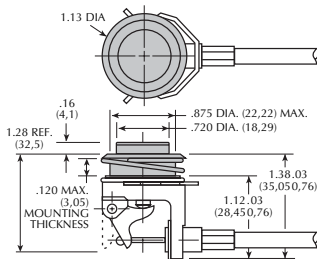

Use End No. 12

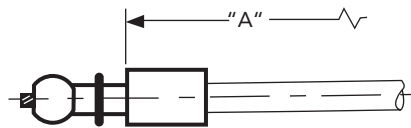

CMA 12129 – Lever Handle/Tube Mount



- Molded and contoured design offers ease of use and maximum actuation force
- Readily mounts to round tubing with one screw
- Easily assembled to CMA standard cable controls
- Positive snap fit conduit-locking feature

12129 – 1 Fits 3/4" round tubing

12129 – 2 Fits 1" round tubing

12129 – 3 Fits 7/8" round tubing

2.5:1 Mechanical advantage

.800" (20.3 mm) travel

Material: Glass filled nylon

Color: Black

Requires #8 type B sheet metal screw

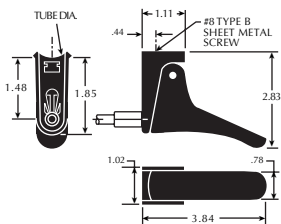

Use Molded End No. 13

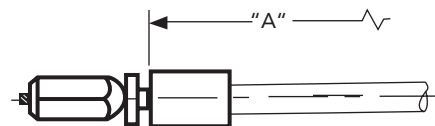



CMA Remote Actuation Systems ACTUATORS

CMA 11767 – D-Ring/Bracket



- Molded design with wide D shape configuration for ease of use in straight pull applications
- Shuttle molded 6-hole hanger bracket for easy mounting to flat surfaces
- Square steel handle shaft eliminates rotation

1.25" MAX (31.75 mm) travel

Material: Polypropylene/Acetal/Steel

Color: Black

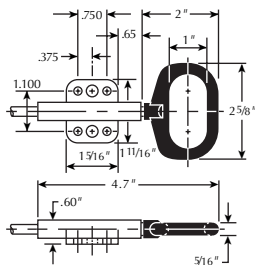

Use Molded End No. 7

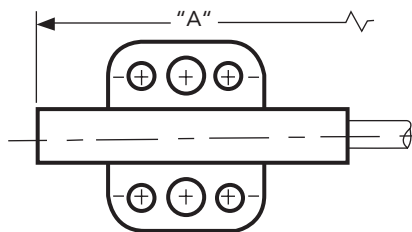

CMA 12073 – T-Handle/Bracket



- Molded design with easy to grip "T" handle for ease of use in straight pull applications
- Shuttle molded 6-hole hanger bracket for easy mounting to flat surfaces
- Square steel handle shaft eliminates rotation

1.25" MAX (31.75 mm) travel

Material: Polypropylene/Acetal/Steel

Color: Black

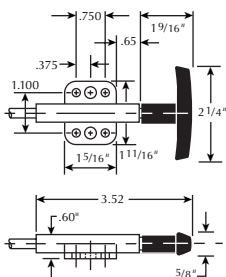

Use Molded End No. 7

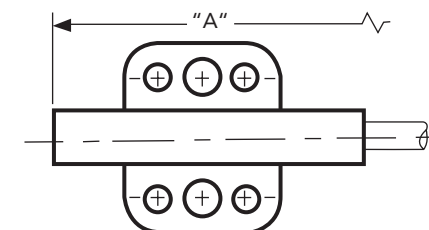



CMA Remote Actuation Systems ACTUATORS

CMA 12169 – Surface Mount Lever Actuator



- Sturdy design with contoured pull up handle
- Easy mounting to the underside of flat surfaces
- Mounting bracket has 2 molded slots for easy installation and adjustment
- Easily assembled to CMA standard cable controls

2.5:1 Mechanical advantage

.625" (15.9 mm) travel

Material: ABS

Color: Black

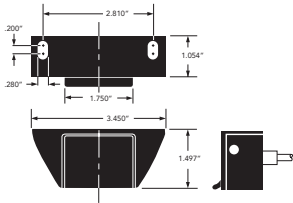

Use Molded End No. 4

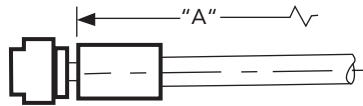



CMA Remote Actuation Systems OPERATORS

CMA 11602-10 – Locking Gas Spring Operator – 10 MM Rod End

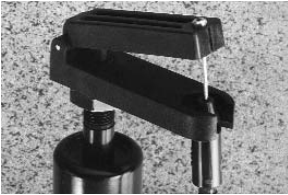

- Molded design for lightweight and ease of assembly
- Used for operating rod end valve stem on locking gas springs
- For use with custom rod end mounting bracket for unique installations
- Designed for intermittent non preload operation of gas spring valve stem
- Readily assembled to CMA standard cable controls

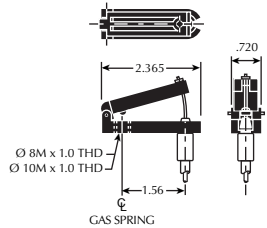

1.57:1 Mechanical advantage

Material: Glass filled nylon

Color: Black

NOTE: For locking gas spring applications, when used with CMA 11603 lever, CMA 11604 push button or CMA 11704 push button – specify a gas spring with quick release valve (1mm travel).

Also available: CMA 11602-8 Locking Gas Spring Operator for 8mm Rod End

Use Molded End No. 2 or No. 11 for Adjustment

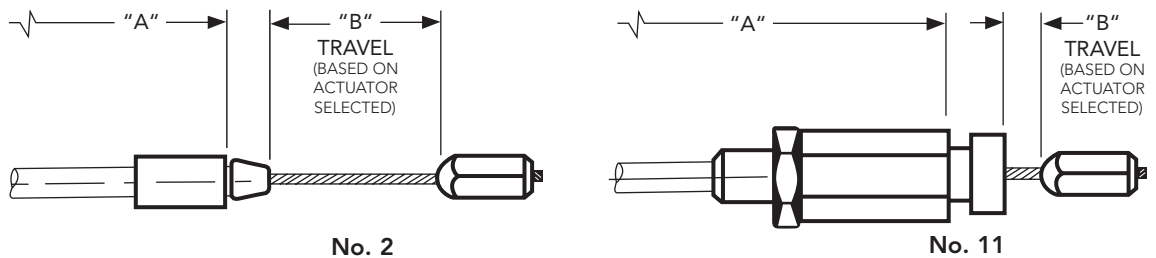

CMA 11708-P110 – Locking Gas Spring Mounting Bracket/Operator – 10 MM Rod End

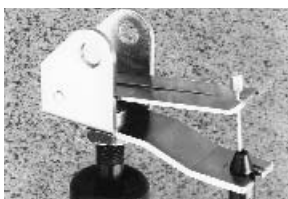

- Integral swivel mounting bracket and operator
- Accepts 8mm Diameter Mounting pin for commonality with gas spring blade end
- Designed to function with locking gas springs up to 1000N applications
- Easily assembled to CMA standard cable controls

5:1 Mechanical advantage

Material: CRS Steel

Finish: Zinc plating with clear chromate

NOTE: For locking gas spring applications, when used with CMA 11603 lever, CMA 11604 push button or CMA 11704 push button – specify a gas spring with quick release valve (1mm travel).

Also available: CMA 11708P – 108 (8mm), CMA 11708P – 10 (10mm) and 11708P – 8 (8mm) Locking Gas Spring Mounting Bracket/Operators for use on Gas Springs with Straight Valve Pin.

Use Molded End No. 2

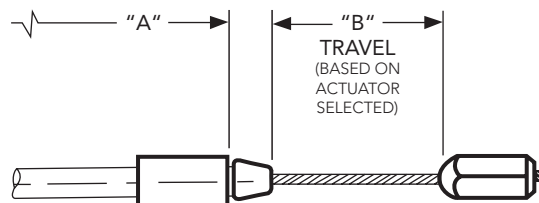



CMA Remote Actuation Systems OPERATORS

CMA 12030-10 – Heavy Duty Locking Gas Spring Operator



- Heavy gauge bracket suitable for higher force locking gas springs and high load mounting geometry
- Supplied assembled to CMA cable controls
- For use with 10 mm diameter rod end gas springs

4.5:1 Mechanical advantage

Material: CRS Steel

Finish: Zinc with clear chromate

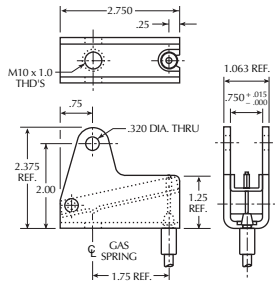

NOTE: For locking gas spring applications, when used with CMA 11603 lever, CMA 11604 push button or CMA 11704 push button – specify a gas spring with quick release valve (1mm travel).

Use Molded End No. 2

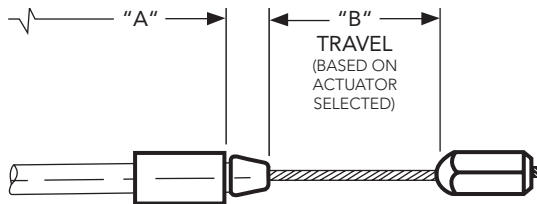

CMA 12076-10 – BLOC-O-LIFT® Release Mechanism



- Compact release head for space constrained applications
- For use with Stabilus BLOC-O-LIFT locking gas springs only
- Assemblies to CMA custom cable controls
- Recommended for use with a maximum of 500N force BLOC-O-LIFTS

2.32:1 Mechanical advantage

Material: Die cast zinc/aluminum

Finish: As Cast

Also available: CMA 12076-8 (8mm)

Release Head: 10mm – Stabilus P/N 784575 8mm – Stabilus P/N 983918

Lever: Used for both – Stabilus P/N 783234

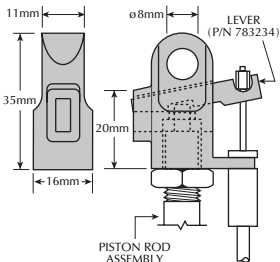

Use Molded End No. 10

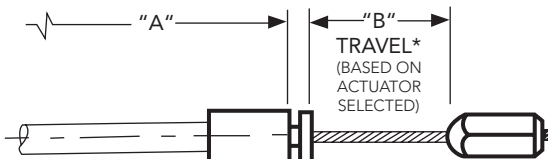



CMA Remote Actuation Systems OPERATORS

CMA 12077 – Compact Locking Gas Spring Operator



- For use with special rod end Stabilus BLOC-O-LIFT® locking gas springs in specialty seating applications
- Compact design for space constrained applications
- Supplied assembled to CMA standard cable controls

3.5:1 Mechanical advantage

Material: Glass filled nylon/C1070 Steel

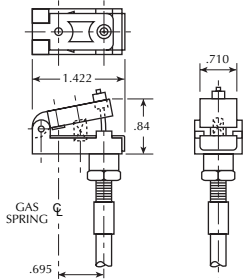

Use End No. 9

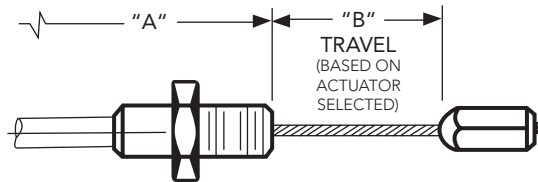

CMA 81-222P – Dual Cable Control Adapter

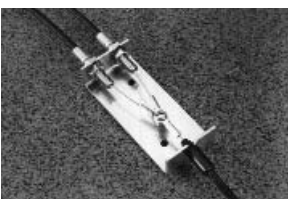

- Design permits multiple actuator or operator use
- Bracket mounts to flat surface with two mounting holes provided
- Easily assembled to CMA standard cable controls
- Used with conduit end No. 6 which provides adjustability to remove cable slack and to balance system

Material: C1010 Steel

Finish: Zinc plating with clear chromate

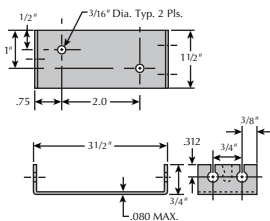

Use Molded End No. 5
and End No. 6

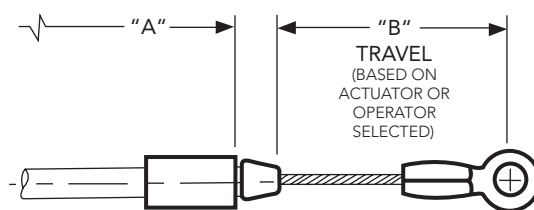

No. 5

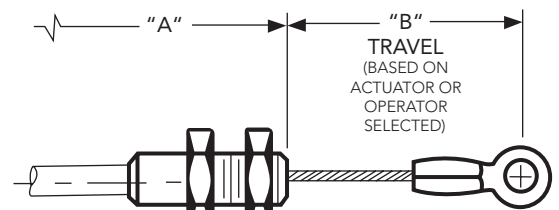

No. 6



CMA Remote Actuation Systems OPERATORS

CMA 99-SERIES – Conduit Clamps



- Suitable for use with CMA cable controls
- Single fastener installation
- Dimples keep conduit positioned

Material: Galvanized steel

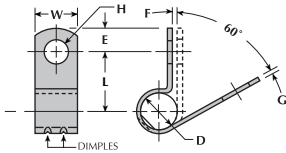

Part No.	D Ref. Clamping Dia./ Conduit O.D.	H ± .010/ 0.25 in./ mm	L Ref.	W Ref.	E Ref.	F Ref.	G ±.005/ 0.13 in./ mm
99-568 P	.188	9/32/ 7.14	3/8	1/2	1/4	1/32	0.32/ 0.81
99-595 P	.188	13/64/ 5.16	3/8	1/2	7/32	1/32	0.32/ 0.81
99-561 P	.219	9/32/ 7.14	3/8	1/2	1/4	1/32	0.32/ 0.81



CMA 97 SERIES MOLDED FITTINGS

www.cmacable.com/specs/cma86

END COUPLING

PART NO.	RECOMMENDED CONDUIT	MAX. Cable Dia. in./mm	MAX. Core Dia. in./mm	MATERIAL
97-509	C002	.047/ 1.19	.047/ 1.19	Nylon-Black
	C006	.047/ 1.19	.047/ 1.19	
97-521	C003	.063/ 1.60	.054/ 1.37	Nylon-Black
	C007	.063/ 1.60	.062/ 1.57	
	C010	.063/ 1.60	.054/ 1.37	

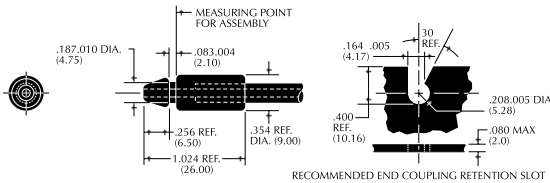

END COUPLING

PART NO.	RECOMMENDED CONDUIT	MAX. Cable Dia. in./mm	MAX. Core Dia. in./mm	MATERIAL
97-537	C002	.047/ 1.19	.047/ 1.19	Nylon-Black
	C006	.047/ 1.19	.047/ 1.19	
97-538	C003	.063/ 1.60	.054/ 1.37	Nylon-Black
	C010	.063/ 1.60	.054/ 1.37	
97-539	C015	.047/ 1.19	.047/ 1.19	
97-671	C007	.063/ 1.60	.062/ 1.57	

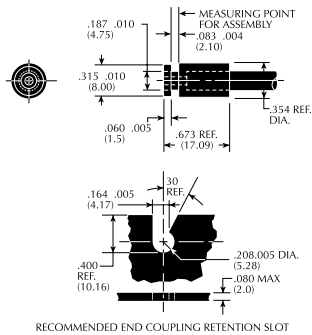

END COUPLING

PART NO.	RECOMMENDED CONDUIT	MAX. Cable Dia. in./mm	MAX. Core Dia. in./mm	MATERIAL
97-520	C008	.038/ 0.97	.038/ 0.97	Nylon-Black

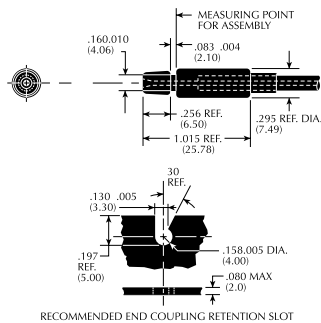

SNAP-IN BUSHING

PART NO.	RECOMMENDED CONDUIT	MAX. Cable Dia. in./mm	MAX. Core Dia. in./mm	MATERIAL
97-594	C003	.063/ 1.60	.054/ 1.37	Nylon-Black
	C010	.063/ 1.60	.054/ 1.37	
97-617	C002	.047/ 1.19	.047/ 1.19	Nylon-Black
	C006	.047/ 1.19	.047/ 1.19	

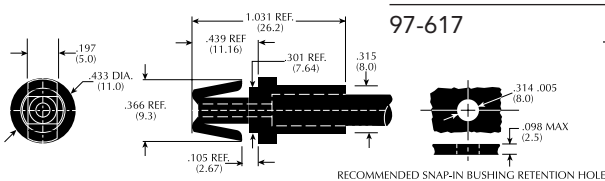



CMA 97 SERIES MOLDED FITTINGS

www.cmacable.com/specs/cma86

SNAP-IN BUSHING	PART NO.	RECOMMENDED CONDUIT	MAX. Cable Dia. in./ mm	MAX. Core Dia. in./ mm	MATERIAL
	97-540	C003	.063/ 1.60	.054/ 1.37	Nylon-Black
		C010	.063/ 1.60	.054/ 1.37	Nylon-Black

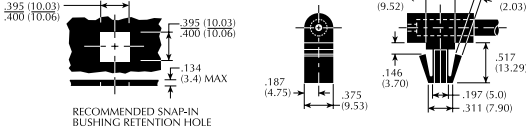

SNAP-IN BUSHING	PART NO.	RECOMMENDED CONDUIT	MAX. Cable Dia. in./ mm	MAX. Core Dia. in./ mm	MATERIAL
	97-610	C003	.063/ 1.60	.054/ 1.37	Nylon-Glass
		C010	.063/ 1.60	.054/ 1.37	Filled Black

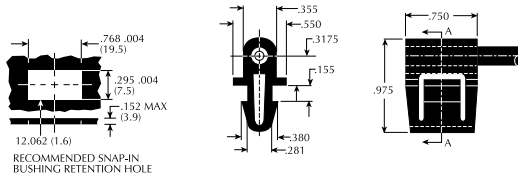

SNAP-IN BUSHING	PART NO.	RECOMMENDED CONDUIT	MAX. Cable Dia. in./ mm	MAX. Core Dia. in./ mm	MATERIAL
	97-522	C005	.047/ 1.19	.054/ 1.37	Nylon-Black

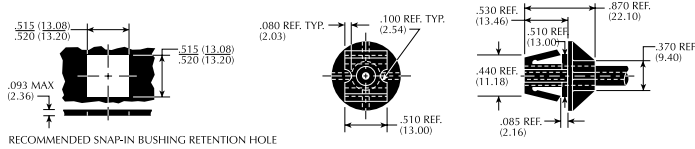

COLLAR	PART NO.	RECOMMENDED CONDUIT	MAX. Cable Dia. in./ mm	MAX. Core Dia. in./ mm	MATERIAL
	97-523	C005	.047/ 1.19	.054/ 1.37	Nylon-Black

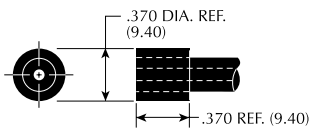

PUSH-IN BUSHING	PART NO.	RECOMMENDED CONDUIT	MAX. Cable Dia. in./ mm	MAX. Core Dia. in./ mm	MATERIAL
	97-624	C002	.047/ 1.19	.047/ 1.19	Nylon-Black
		C006	.047/ 1.19	.047/ 1.19	

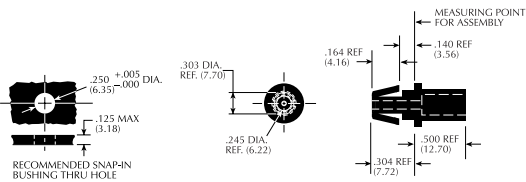

SLOTTED FLAG	PART NO.	RECOMMENDED CONDUIT	MAX. Cable Dia. in./ mm	MAX. Core Dia. in./ mm	MATERIAL
	97-518	C003	.063/ 1.60	.054/ 1.37	Nylon-Glass
		C007	.063/ 1.60	.062/ 1.57	
		C010	.063/ 1.60	.054/ 1.37	

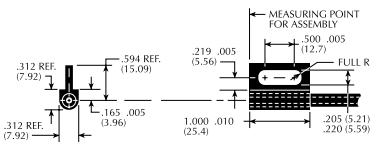



CMA 93 SERIES THREADED CONDUIT FITTING

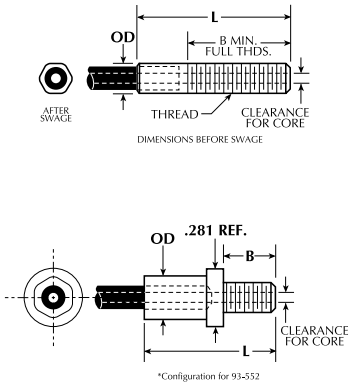

PART NO.	CONDUIT OD REF. in./mm	L REF. BEFORE SWAGE	B MIN. in./mm	OD REF. BEFORE SWAGE	THREAD
93-535	.188/ 4.78	1.31	.71/ 18.03	.250	M6x1.0
93-515	.188/ 4.78	1.40	.75/ 19.05	.250	1/4-28
93-543	.203/ 5.16	1.38	.71/ 18.03	.312	5/16-24
93-544	.203/ 5.16	1.38	.71/ 18.03	.312	5/16-24 LH
93-551	.203/ 5.16	1.50	.90/ 22.86	.281	1/4-20
93-552*	.203/ 5.16	.85	.35/ 8.9	.281	1/4-20
93-556	.203/ 5.16	1.60	1.00/ 25.4	.312	M6x1.0
93-532	.219/ 5.56	1.35	.75/ 19.05	.312	5/16-24
93-513	.219/ 5.56	2.25	1.50/ 38.10	.312	5/16-24
93-545	.219/ 5.56	2.09	1.38/ 35.05	.375	3/8-24
93-546	.262/ 6.65	1.35	.75/ 19.05	.437	5/16-24
93-533	.262/ 6.65	2.00	1.38/ 35.05	.437	5/16-24

- NOTES:** 1. Dimensions shown are "before swage".
2. For conduit diameters less than .188 (4.78) contact CMA (Miniature and ultra-light applications).
3. May be used loose or swaged.

CMA 95 SERIES SNAP RING CONDUIT FITTING

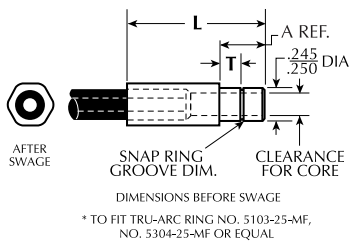

PART NO.	CONDUIT OD REF. in./mm	L REF. BEFORE SWAGE	T REF. THICKNESS OF MOUNTING	A REF.	SNAP RING GROOVE DIM.
95-520	.188/ 4.78	.930	.190	.290	.039x.210 DIA*
95-525	.203/ 5.16	.930	.220	.320	.029x.220 DIA
95-527	.203/ 5.16	.930	.050	.140	.029x.188 DIA
95-529	.203/ 5.16	.860	.150	.250	.029x.220 DIA
95-528	.218/ 5.54	.950	.110	.210	.040x.220 DIA*
95-521	.219/ 5.56	.950	.190	.290	.039x.210 DIA*
95-522	.262/ 6.65	.930	.190	.290	.039x.210 DIA*

- NOTES:** 1. Dimensions shown are "before swage".
2. For conduit diameters less than .188 (4.78) contact CMA (Miniature and ultra-light applications).
3. May be used loose or swaged.



CMA 93 SERIES THREADED CONDUIT FITTING

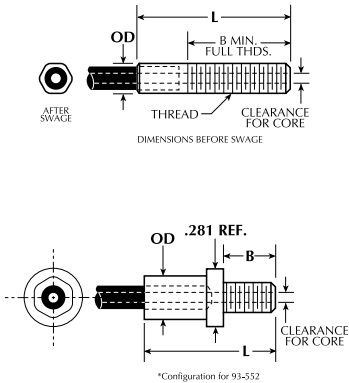

PART NO.	CONDUIT OD REF. in./mm	L REF. BEFORE SWAGE	B MIN. in./mm	OD REF. BEFORE SWAGE	THREAD
93-535	.188/ 4.78	1.31	.71/ 18.03	.250	M6x1.0
93-515	.188/ 4.78	1.40	.75/ 19.05	.250	1/4-28
93-543	.203/ 5.16	1.38	.71/ 18.03	.312	5/16-24
93-544	.203/ 5.16	1.38	.71/ 18.03	.312	5/16-24 LH
93-551	.203/ 5.16	1.50	.90/ 22.86	.281	1/4-20
93-552*	.203/ 5.16	.85	.35/ 8.9	.281	1/4-20
93-556	.203/ 5.16	1.60	1.00/ 25.4	.312	M6x1.0
93-532	.219/ 5.56	1.35	.75/ 19.05	.312	5/16-24
93-513	.219/ 5.56	2.25	1.50/ 38.10	.312	5/16-24
93-545	.219/ 5.56	2.09	1.38/ 35.05	.375	3/8-24
93-546	.262/ 6.65	1.35	.75/ 19.05	.437	5/16-24
93-533	.262/ 6.65	2.00	1.38/ 35.05	.437	5/16-24

- NOTES:** 1. Dimensions shown are "before swage".
2. For conduit diameters less than .188 (4.78) contact CMA (Miniature and ultra-light applications).
3. May be used loose or swaged.

CMA 95 SERIES SNAP RING CONDUIT FITTING

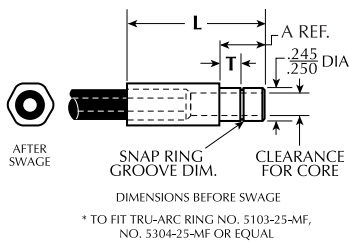

PART NO.	CONDUIT OD REF. in./mm	L REF. BEFORE SWAGE	T REF. THICKNESS OF MOUNTING	A REF.	SNAP RING GROOVE DIM.
95-520	.188/ 4.78	.930	.190	.290	.039x.210 DIA*
95-525	.203/ 5.16	.930	.220	.320	.029x.220 DIA
95-527	.203/ 5.16	.930	.050	.140	.029x.188 DIA
95-529	.203/ 5.16	.860	.150	.250	.029x.220 DIA
95-528	.218/ 5.54	.950	.110	.210	.040x.220 DIA*
95-521	.219/ 5.56	.950	.190	.290	.039x.210 DIA*
95-522	.262/ 6.65	.930	.190	.290	.039x.210 DIA*

- NOTES:** 1. Dimensions shown are "before swage".
2. For conduit diameters less than .188 (4.78) contact CMA (Miniature and ultra-light applications).
3. May be used loose or swaged.



CMA 96 SERIES PLAIN CONDUIT FITTING

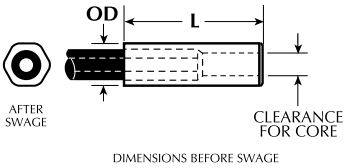

PART NO.	CONDUIT OD REF. in./mm	L REF. BEFORE SWAGE	OD REF. BEFORE SWAGE
96-510	.188/ 4.78	1.00	.250
96-511	.188/ 4.78	.875	.312
96-512	.219/ 5.56	.875	.312
96-513	.262/ 6.65	.875	.375

- NOTES:** 1. Dimensions shown are "before swage".
2. For conduit diameters less than .188 (4.78) contact CMA (Miniature and ultra-light applications.)
3. May be used loose or swaged.

CMA 99 SERIES CONDUIT CLAMPS

PART NO.	D REF. CLAMPING DIA. CONDUIT OD	H ±.010/ 0.25 in./mm	L REF.	W REF.	E REF.	F REF.	G ±.005/0.13 in./mm	S REF.	TYPE
99-568	.188	9/32/ 7.14	3/8	1/2	1/4	1/32	.032/ 0.81	-	W/Dimples
99-595	.188	13/64/ 5.16	3/8	1/2	7/32	1/32	.032/ 0.81	-	W/Dimples
99-561	.219	9/32/ 7.14	3/8	1/2	1/4	1/32	.032/ 0.81	-	W/Dimples
99-547	.250	11/32/ 8.73	19/32	5/8	3/8	1/32	.032/ 0.81	7/16	Cushioned
99-549	.250	11/32/ 8.73	9/16	5/8	3/8	1/32	.032/ 0.81	7/16	Plain
99-599	.250	9/32/ 7.14	17/32	1/2	5/16	1/32	.032/ 0.81	3/8	Cushioned
99-600	.250	11/64/ 4.37	11/32	3/8	3/16	1/16	.032/ 0.81	-	Plain
99-597	.319	9/32/ 7.14	17/32	1/2	5/16	1/32	.032/ 0.81	3/8	Plain

